



USER MANUAL

MS/MSE3/YE3/MSE4/MSEJ/MYT

ÉKSZÍJ.HU

MS, MSE3, YE3 and MSE4 series

Three-phase asynchronous electric motor



MSEJ series

Three-phase, asynchronous electric brake motor

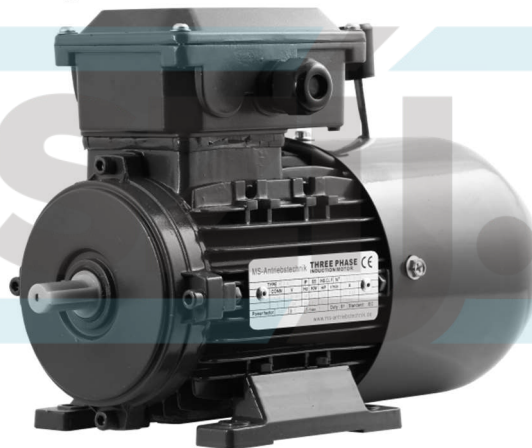

MYT series

Single-phase asynchronous electric motor



Standards and norms

MORGENSEN electric motors comply with the EU and international standards and norms listed below :

Name	CEI	IEC
General requirements for rotating machinery	CEI EN 60034-1	IEC 60034-1
Direction of rotation and terminal box marking for rotating machines	CEI 2-8	IEC 600034-08
Cooling mode for rotating machines	CEI EN 60034-6	IEC 60034-6
Rated power for rotating machines	EN 50347	IEC 60072
Degree of IP protection of rotating machines	CEI EN 60034-5	IEC 60034-5
Noise level	CEI EN 60034-9	IEC 60034-9
Classification of building forms and construction type	CEI EN 60034-7	IEC 60034-7
Rated voltage for low voltage supply	CEI 8-6	IEC 60038
Vibration level for electrical machines	CEI EN 60034-14	IEC 60034-14

Mechanical tolerances

Notation	Description	Tolerance
A, B	Bore center distances on the soleplate	+/- 1 mm
AB, AC	Maximum electric motor diameter	+ 2%
C	The distance between the front hole center and the flange	+/- 3 mm
D	Electric motor shaft diameter - 9 - 48 mm	k6
D	Electric motor shaft diameter - above 55 mm	m6
E	Shaft length - 9 - 48 mm for shaft diameter	- 0.3 mm
E	Shaft length - for shaft diameters greater than 55 mm	+ 0.5 mm
F	Latch width	h9
H	Shaft center height from the plane of the base 56 - 250 mm	- 0.5 mm
H	Axle center height above the plane of the base 250 mm	- 1 mm
K, S	Mounting hole diameters	+ 3%
L	The total length of the electric motor	+ 1%
LB	Total length of braked electric motor	+ 1%
M	Hole spacing of electric motor manifold flange	+/- 0.8 mm
N	Electric motor adapter flange diameter up to 230 mm	j6
N	Electric motor adapter flange diameter from 250 mm	h6
P	Electric motor outer rim diameter	+/- 1 mm
m	Weight of electric motor	-5% - + 10%

General Information

The MORGENSEN electric motors sold by Motor-Systems Kft. Have the properties according to the IEC standards, which are valid for S1 (continuous) operation, nominal voltage and frequency values, maximum ambient temperature 40 ° C and maximum operating altitude 1000 m above sea level.

Our electric motors have the following electrical properties:

Electrical feature	Value
Tension	230/400 V - Δ / Y 400/690 V - Δ / Y 230 V
Frequency	50 Hz
Efficiency 0.09 - 0.55 kW	IE1 is general
Efficiency 0.75 - 315 kW	IE3 premium efficiency
Protection	IP55
Insulation class	F - 155 ° C

Mechanical properties:

Parts	Electric motor housing size	
	56 - 132	160 - 355
Electric motor housing	Cast aluminum	cast iron
Electric motor base	Aluminum can be removed and rotated 90 °	cast iron, not mountable
Peremek	Aluminum with reinforced bearing housing	cast iron with grease nipple
Electric motor shaft	Hardened steel, latch, shaft end bore	Hardened steel, latch, shaft end bore
Bearings	Lifetime lubricated ball bearing	Lifetime lubricated ball bearing, sizes 315 and 355 up to 4-8p NU bearings on the drive side
Oil seal	Both on the drive side and on the opposite side of the drive in all sizes	Both on the drive side and on the opposite side of the drive in all sizes
Painting	Epoxy, blue color - RAL 5010	Epoxy, blue color - RAL 5010

It is also possible to supply electric motors other than the specified electrical or mechanical values. If you need such a special electric motor, please call our colleagues.

IE3 premium efficiency

In accordance with Regulation (EC) No 640/2009, engines purchased after 1 January 2017 with a rated output of 0.75 kW and up to 375 kW shall not be less than the efficiency values of efficiency category IE3 in mains operation, or the motor shall be equipped with a frequency converter. and meet the requirements of efficiency category IE2.

IE4 super premium efficiency

Morgensen's new MSE4 super premium efficiency electric motors have 15% less power loss than their IE3 counterparts, so they already meet the requirements of the IE4 efficiency class of electric motors according to IEC / CD 60034-30 Ed. 2 required by the European Union.

Exploded view

The following figure shows the components of the MS, MSE3 and MYT series electric motors and their assembly:

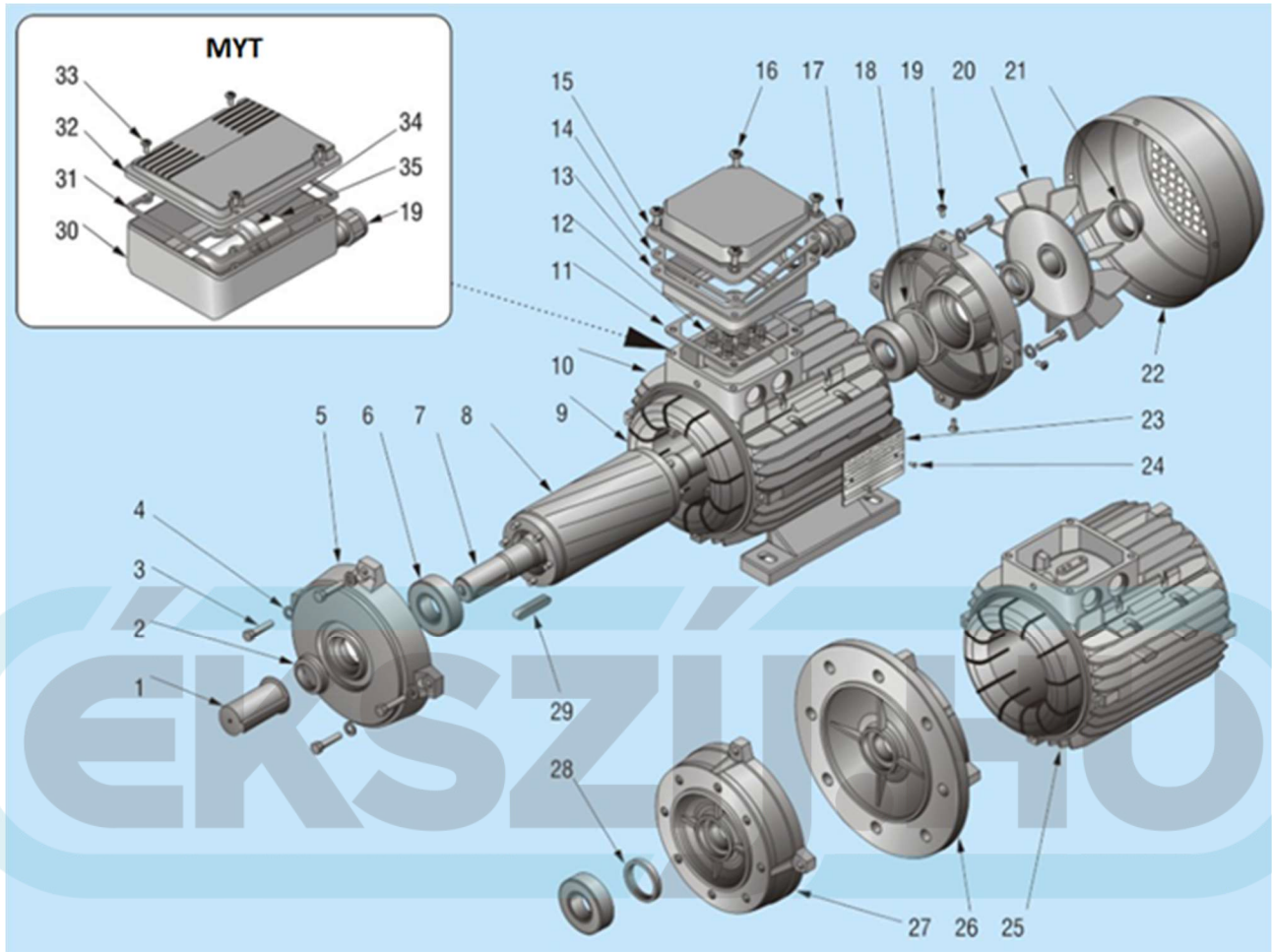

No	Name	No	Name	No	Name
1	Shaft protection cap	13	Terminal box	25	Engine housing B5 and B14
2	V-ring	14	Terminal cover seal IP65	26	Engine shield B5
3	Engine compression bolt	15	Terminal cover	27	Engine shield B14
4	Spring washer	16	Clamp cover fixing screw	28	Oil seal
5	Engine shield B3	17	Gland	29	Latch
6	Bearing	18	Spacer ring	30	Terminal block (MYT)
7	Motor shaft	19	Engine shield mounting bolt	31	Terminal Cover Gasket (MYT)
8	Rotor	20	Fan blade	32	Terminal cover (MYT)
9	Stator coil	21	Fan blade retaining ring	33	Terminal Cover Retaining Screw (MYT)
10	Engine housing	22	Fan cover	34	Capacitor clamp (MYT)
11	Terminal cover seal IP55	23	Data table	35	Capacitor (MYT)
12	Terminal block	24	Nameplate mounting screw		

Wiring methods

Wiring methods for three-phase, single-speed asynchronous electric motors

The 3 pcs. phase conductor to points U1-V1-W1 of the electric motor, the protective earth must be connected to the earthing screw by means of cable lugs. The terminal strips are connected to the winding of the electric motor and to the mains voltage. - if present, be located according to the voltage delivered by the frequency converter. When starting an electric motor directly, in the case of a 3x400V network, 230 / 400V winding electric motors must be connected to a star, 400 / 690V winding electric motors to a delta connection.

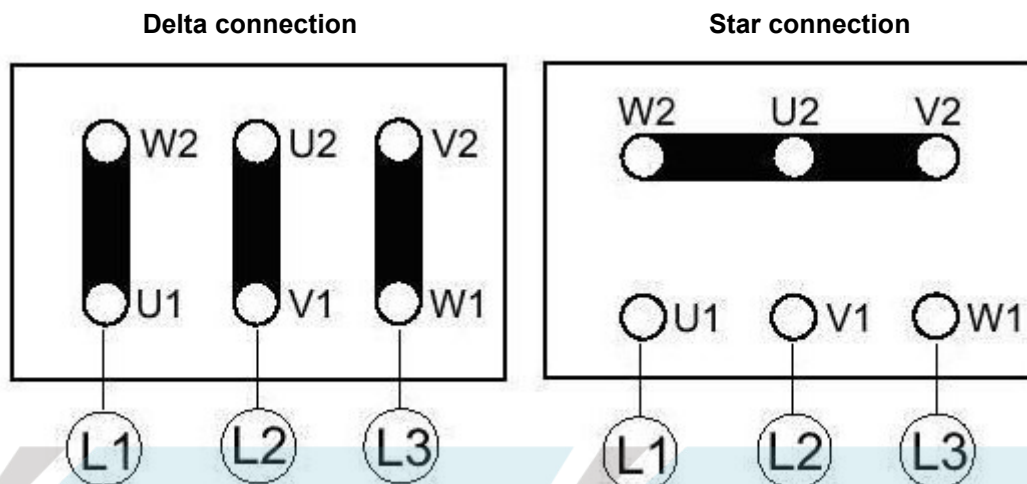

Changing the direction of rotation of a three-phase electric motor

The direction of rotation of three-phase electric motors can be changed by reversing the connection order of any two of the three phase conductors.

Changing the speed of a three-phase electric motor

The speed of a three-phase asynchronous electric motor can be controlled using a frequency converter. We can also drive 230 / 400V coil electric motors with 1x230V and 3x400V frequency inverters. In the former case, the electric motor must be connected to delta, in the second case to star. Electric motors with 400 / 690V windings can only be driven by a frequency converter with a 3x400V supply, the electric motor must be connected to a delta connection.

Wiring methods for single-phase asynchronous electric motors

In the case of single-phase electric motors, the phase and neutral conductors - in any order - must be connected to points U1, U2, the earth cable to the earthing screw using cable lugs.

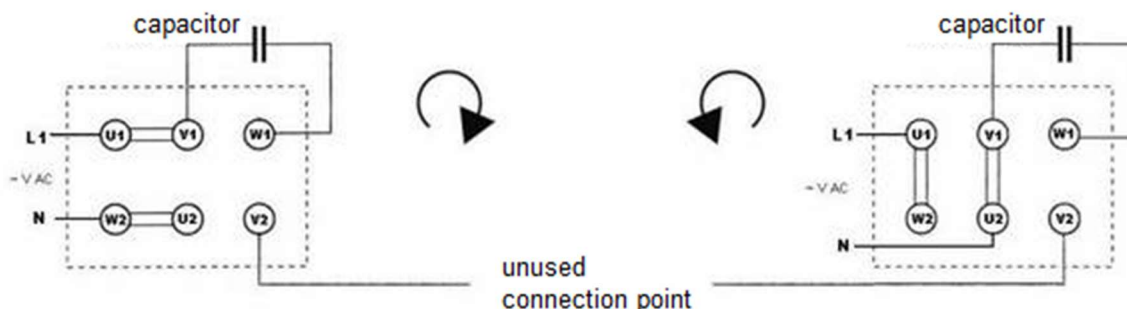

Changing the direction of rotation of a single-phase electric motor

The direction of rotation of single-phase electric motors can be changed by swapping the two end points of the auxiliary phase.

Installation positions

Our electric motors are B3 – foot mounted, B14 - small flange and B5 - large flange, respectively. they are delivered in combinations and can be installed in the following positions according to CEI EN 60034-7:

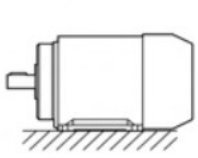

B3

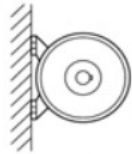

B6

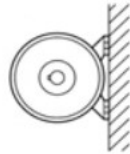

B7

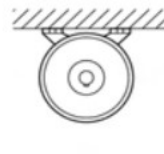

B8

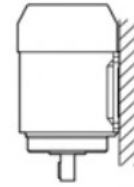

V5

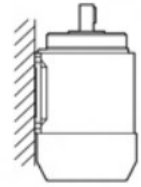

V6

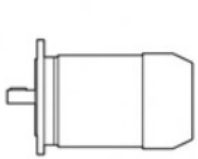

B5

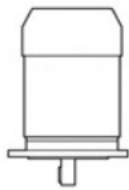

V1



V3

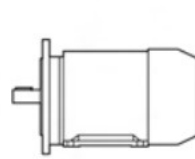

B35

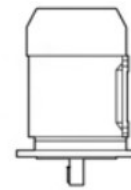

V1/V5

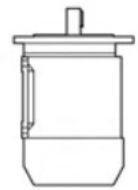

V3/V6

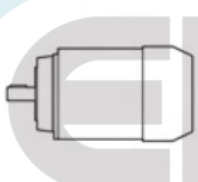

B14



V18



V19

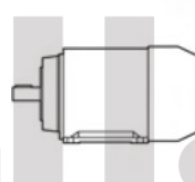

B34



V18/V5



V19/V6

Bearings

The following table shows the bearing sizes of the electric motors we sell:

Size	Pole	Drive end	Non drive end
56	2-4-6-8	6201 - 2ZC3	6201 - 2ZC3
63	2-4-6-8	6201 - 2ZC3	6201 - 2ZC3
71	2-4-6-8	6202 - 2ZC3	6202 - 2ZC3
80	2-4-6-8	6204 - 2ZC3	6204 - 2ZC3
90	2-4-6-8	6205 - 2ZC3	6205 - 2ZC3
100	2-4-6-8	6206 - 2ZC3	6206 - 2ZC3
112	2-4-6-8	6306 - 2ZC3	6306 - 2ZC3
132	2-4-6-8	6308 - 2ZC3	6308 - 2ZC3
160	2-4-6-8	6309 - 2ZC3	6309 - 2ZC3
180	2-4-6-8	6311 - C3	6311 - C3
200	2-4-6-8	6312 - C3	6312 - C3
225	2-4-6-8	6313 - C3	6313 - C3
250	2-4-6-8	6314 - C3	6314 - C3
280	2	6314 - C3	6314 - C3
	4-6-8	6317 - C3	6317 - C3
315	2	6317 - C3	6317 - C3
	4-6-8	NU319 - C3	6319 - C3
355	2	6319 - C3	6319 - C3
	4-6-8	NU322 - C3	6322 - C3

Lubrication

Our electric motors up to housing sizes 56-160, up to an ambient temperature of 40 ° C are equipped with long-life greased, sealed bearings. Above 40 ° C, special heat-resistant greasing is recommended. Above housing size 160, electric motors are equipped with a grease nipple for subsequent greasing.

Ambient temperature

The power data of the electric motors we sell are valid at a frequency of 50 Hz in accordance with the CEI EN 60034-1 standard at an ambient temperature of -15 to +40 ° C and up to an operating altitude of 1000 m above sea level. For operation above 40 ° C ambient temperature, the power reduction according to the following table must be taken into account:

Ambient temperature	40 ° C	45 ° C	50 ° C	55 ° C	60 ° C
Permissible power compared to the rated	100%	95%	90%	85%	80%

Electric motor protections

Although the design of motor protection is proportionally higher for lower power electric motors, we always recommend the installation of professional motor protection.

The following electric motor protections are available on request:

- PTC - From housing size 160, PTC thermal protection is standard on our electric motors. If required, it can be installed in any motor, even retrofitted.
- Bimetal temperature probe
- PT100 bearing temperature probe
- Heating resistor in the coils
- Insulated bearing drive on opposite side - for frequency converter operation recommended for electric motors larger than 280 housing sizes

Braking torque values for electric motors with MSEJ series brakes

Our braked electric motors with DC brakes have a rectifier built into the terminal board, so it is much easier to use, there is no need to power the brake separately. In addition, all our brake motors are equipped with a manual brake release lever, so the brake can be easily released even in the event of a power failure.

The MORGENSEN braked electric motors we sell have the following braking torques:

Power [kW]	Braking torque [Nm]
0.18	4
0.25	4
0.37	4
0.55	8
0.75	8
1.1	15
1.5	15
2.2	30
3	30
4	40
5.5	75
7.5	75
11	100
15	100

Specifications

MS, MSE3 and YE3 - three-phase electric motors
MSEJ - electric motors with brakes



Specifications

MS, MSE3 and YE3 - three-phase electric motors and MSEJ - braked electric motors

2p - 3000 rpm

Type	Power		Speed n [1 minute]	Efficiency			cosφ	Nom. current.	Starting current	Nom. torque	Starting torque	Tilting torque	Weight [kg]
	[kW]	[HP]		η 100%	η 75%	η 50%		In 400V [THE]	Is / In	Mn [Nm]	Ms / Mn	Mmax / Mn	
56A2	0.09	0.12	2750	62.0			0.77	0.27	5.2	0.31	2.1	2.2	3.6
56B2	0.12	0.18	2750	64.0			0.78	0.35	5.2	0.41	2.1	2.2	3.9
63A2	0.18	0.25	2720	65.0			0.8	0.5	5.5	0.61	2.2	2.3	4.8
63B2	0.25	0.37	2720	68.0			0.81	0.66	5.5	0.96	2.2	2.3	5.1
71A2	0.37	0.5	2750	70.0			0.81	0.94	6.1	1.26	2.2	2.3	6
71B2	0.55	0.75	2740	73.0			0.82	1.33	6.1	1.88	2.2	2.3	6.5
80A2	0.75	1	2890	80.7	80.3	77.2	0.81	1.7	6	2.5	2.7	2.8	8.4
80B2	1.1	1.5	2890	82.7	82.5	79.9	0.82	2.4	6.7	3.7	2.7	2.9	10.2
90S2	1.5	2	2900	84.2	83.8	81.4	0.82	3.1	6.1	5	2.3	2.7	14.4
90L2	2.2	3	2910	85.9	86.1	84.7	0.84	4.4	7	7.4	2.6	2.7	16.2
100L2	3	4	2910	87.1	87.5	86.3	0.88	5.7	7.6	10.1	2.5	2.8	18.5
112M2	4	5.5	2920	88.1	88.2	87	0.9	7.3	7.8	13.1	2.5	2.7	30.2
132SA2	5.5	7.5	2930	89.2	89.4	88.2	0.89	10	7.8	18.1	2.4	2.9	44.1
132SB2	7.5	10	2930	90.1	90.2	89.1	0.9	13.4	7.9	24.6	2.7	2.8	52
160MA2	11	15	2940	91.2	91.1	89.8	0.89	19.6	8.1	35.7	2	2.3	115
160MB2	15	20	2940	91.9	91.8	90.7	0.89	26.5	8.1	48.7	2	2.3	125
160L2	18.5	25	2940	92.4	92.3	90.4	0.89	32.5	8.2	60.1	2	2.3	147
180M2	22	30	2955	92.7	92.6	91.6	0.89	38.5	8.2	71.1	2	2.3	195
200LA2	30	40	2965	93.3	93.2	92.1	0.89	52.1	7.6	96.6	2	2.3	243
200LB2	37	50	2965	93.7	93.5	92.3	0.89	64	7.6	119.2	2	2.3	258
225M2	45	60	2970	94	93.6	92.4	0.9	76.8	7.7	144.7	2	2.3	324
250M2	55	75	2975	94.3	94.1	93	0.9	93.5	7.7	176.6	2	2.3	432
280S2	75	100	2975	94.7	94.3	93	0.9	127	7.1	240.8	1.8	2.3	560
280M2	90	125	2975	95	94.6	94.3	0.9	151.9	7.1	288.9	1.8	2.3	603
315S2	110	150	2980	95.2	94.8	93.6	0.9	185.3	7.1	352.5	1.8	2.3	880
315M2	132	180	2980	95.4	95	93.9	0.9	221.9	7.1	423	1.8	2.3	960
315LA2	160	220	2980	95.6	95	94.2	0.91	265.5	7.2	512.8	1.8	2.3	1030
315LB2	200	270	2980	95.8	95.1	94.2	0.91	331.1	7.2	640.9	1.8	2.2	1358
355MB2	250	340	2980	95.8	95.2	94.5	0.9	413.9	7.2	801.2	1.6	2.2	1802
355LB2	315	430	2980	95.8	95.2	94.5	0.91	521.5	7.2	1009	1.6	2.2	2017

Specifications

MS, MSE3 and YE3 - three-phase electric motors and MSEJ - braked electric motors

4p - 1500 rpm

Type	Power		Speed n [1 minute]	Efficiency			cos ϕ	Nom. current.	Starting current	Nom. torque	Starting torque	Tilting torque	Weight [kg]
	[kW]	[HP]		η 100%	η 75%	η 50%		In 400V [THE]	Is / In	Mn [Nm]	Ms / Mn	Mmax / Mn	
56B4	0.09	0.12	1325	58.0			0.72	0.31	4.0	0.64	2	2.2	3.9
63A4	0.12	0.18	1310	57.0			0.72	0.42	4.4	0.84	2.1	2.3	4.8
63B4	0.18	0.25	1310	60.0			0.73	0.59	4.4	1.26	2.1	2.3	5.1
71A4	0.25	0.37	1320	65.0			0.74	0.75	5.2	1.73	2.1	2.3	6
71B4	0.37	0.5	1330	67.0			0.75	1.06	5.2	2.56	2.1	2.3	6.3
80A4	0.55	0.75	1390	71.0			0.75	1.4	5.2	3.75	2.3	2.3	9.4
80B4	0.75	1	1430	82.5	82.5	80.1	0.7	1.9	5.4	5	2.3	2.9	11.3
90S4	1.1	1.5	1440	84.1	84.2	82.9	0.72	2.6	5.9	7.4	2.3	2.7	15
90L4	1.5	2	1440	85.3	85.5	84.1	0.71	3.6	6.4	10.1	2.4	2.7	18
100LA4	2.2	3	1450	86.7	87.1	86.2	0.82	4.5	6.6	14.7	2.4	2.9	23.3
100LB4	3	4	1450	87.7	88	86.9	0.78	6.4	6.9	20	2.4	2.8	28
112M4	4	5.5	1450	88.6	88.8	88.2	0.82	8	7.9	26.6	2.5	3	32.2
132S4	5.5	7.5	1460	89.6	89.8	89.4	0.84	10.6	7.1	36.7	2.3	2.8	48
132M4	7.5	10	1460	90.4	90.9	90.3	0.85	14.1	7.8	50.1	2.3	2.7	53
160M4	11	15	1465	91.4	91.2	91	0.85	20.4	7.7	71.7	2.2	2.3	130
160L4	15	20	1465	92.1	91.9	91.7	0.86	27.3	7.8	97.8	2.2	2.3	150
180M4	18.5	25	1470	92.6	92.7	91.8	0.86	33.5	7.8	120.2	2	2.3	185
180L4	22	30	1475	93	93.3	92.9	0.86	39.7	7.8	142.4	2	2.3	216
200L4	30	40	1475	93.6	93.3	92.1	0.86	53.8	7.3	194.2	2	2.3	260
225S4	37	50	1480	93.9	94	93.5	0.86	66.1	7.4	238.8	2	2.3	337
225M4	45	60	1480	94.2	94.3	93.8	0.86	80.2	7.4	290.4	2	2.3	344
250M4	55	75	1480	94.6	94.3	93.5	0.86	97.6	7.4	354.9	2.2	2.3	455
280S4	75	100	1485	95	94.7	93.5	0.88	129.5	6.9	482.3	2	2.3	590
280M4	90	125	1485	95.2	94.9	93.7	0.88	155.1	6.9	578.8	2	2.3	634
315S4	110	150	1485	95.4	95.5	94.6	0.89	187	7	707.4	2	2.2	940
315M4	132	180	1485	95.6	95.4	95.1	0.89	223.9	7	848.9	2	2.2	980
315LA4	160	220	1485	95.8	95.5	95.3	0.89	270.9	7.1	1029	2	2.2	1060
315LB4	200	270	1485	96	95.6	95.2	0.9	334.1	7.1	1286	2	2.2	1200
355M4	250	340	1490	96	95.7	95.1	0.9	417.7	7.1	1602	2	2.2	1815
355L4	315	430	1490	96	95.7	95.1	0.9	526.2	7.1	2018	2	2.2	1984
355LB4	355	480	1490	96	95.7	95.1	0.88	606.5	7	2275	1.7	2.2	2291

Specifications

MS, MSE3 and YE3 - three-phase electric motors and MSEJ - braked electric motors

6p - 1000 rpm

Type	Power		Speed n [1 minute]	Efficiency			cos ϕ	Nom. current.	Starting current	Nom. torque	Starting torque	Tilting torque	Weight [kg]
	[kW]	[HP]		η 100%	η 75%	η 50%		In 400V [THE]	Is / In	Mn [Nm]	Ms / Mn	Mmax / Mn	
63B6	0.12	0.18	840	48			0.6	0.59	4	1.00	2.2	2.3	4.1
71A6	0.18	0.25	850	56			0.66	0.7	4.7	1.91	1.9	2	6
71B6	0.25	0.37	850	59			0.68	0.9	4.7	2.65	1.9	2	6.3
80A6	0.37	0.5	885	62			0.7	1.24	5.5	3.93	1.9	2	8.9
80B6	0.55	0.75	885	65			0.72	1.7	5.5	5.84	1.9	2.1	10.4
90S6	0.75	1	945	78.9	80.1	78.1	0.67	2.1	6.2	7.70	2.2	2	14
90L6	1.1	1.5	950	81	81.1	78.4	0.67	2.9	6	11.2	2.3	2.1	16.2
100L6	1.5	2	950	82.5	83	81.8	0.71	3.7	5.8	15.2	2.3	2.1	22
112M6	2.2	3	960	84.3	84.5	83.2	0.72	5.3	6.4	22.4	2.3	2.1	26
132S6	3	4	965	85.6	86	85.1	0.74	6.9	6.3	30.5	2.4	2.2	39
132MA6	4	5.5	970	86.8	87.1	86.2	0.74	9	6.2	40.4	2.5	2	47.2
132MB6	5.5	7.5	970	88	88.3	87.1	0.75	12.1	6.8	55.6	2.3	1.9	55.4
160M6	7.5	10	970	89.1	89.2	87.8	0.79	15.4	7	73.8	2	2.1	119
160L6	11	15	970	90.3	90.5	89.4	0.8	22	7.2	108.3	2	2.1	148
180L6	15	20	975	91.2	91.4	90.8	0.81	29.3	7.3	146.9	2	2.1	197
200LA6	18.5	25	975	91.7	92	91.4	0.81	36	7.3	181.2	2	2.1	230
200LB6	22	30	975	92.2	92.4	91.9	0.81	42.5	7.4	215.5	2	2.1	251
225M6	30	40	985	92.9	93.1	92	0.83	56.2	6.9	290.9	2	2.1	330
250M6	37	50	985	93.3	93.3	92.5	0.84	68.1	7.1	358.7	2	2.1	426
280S6	45	60	985	93.7	92.6	91.4	0.85	81.6	7.3	436.3	2	2	535
280M6	55	75	985	94.1	93.9	93	0.86	98.1	7.3	533.2	2	2	576
315S6	75	100	990	94.6	94.5	93.8	0.84	136.2	6.6	723.5	2	2	840
315M6	90	125	990	94.9	94.7	94.1	0.85	161	6.7	868.2	2	2	900
315LA6	110	150	990	95.1	94.9	94.6	0.85	196.4	6.7	1061	2	2	980
315LB6	132	180	990	95.4	95.1	94.7	0.86	232.2	6.8	1273	2	2	1100
355MA6	160	220	990	95.6	95.3	94.5	0.86	280.9	6.8	1543	1.8	2	1709
355MB6	200	270	990	95.8	95.4	94.6	0.87	346.4	6.8	1929	1.8	2	1945
355LB6	250	340	990	95.8	95.4	94.6	0.87	433	6.8	2411	1.8	2	2092

Specifications

MS, MSE3 and YE3 - three-phase electric motors and MSEJ - braked electric motors

8p - 750 rpm

Type	Power		Speed n [1 minute]	Efficiency		Nom. current. In 400V [THE]	Starting current Is / In	Nom. torque Mn [Nm]	Starting torque Ms / Mn	Tilting torque Mmax / Mn	Weight [kg]
	[kW]	[HP]		η 100%	cos ϕ						
71M8	0.12	0.18	680	51	0.6	0.58	3.3	1.8	1.8	2.3	6
80M1-8	0.18	0.25	680	51	0.66	0.83	3.3	2.7	1.8	2	8
80M2-8	0.25	0.37	680	56	0.68	1.1	3.3	3.7	1.8	2	10
90S8	0.37	0.5	680	63	0.7	1.49	4	5.2	1.8	2	11
90L8	0.55	0.75	680	66	0.72	2.17	4	7.7	1.8	2.1	12.5
100L1-8	0.75	1	710	66	0.67	2.43	4	10.5	1.8	2	19
100L2-8	1.1	1.5	710	72	0.67	3.36	5	15.4	1.8	2.1	21.5
112M8	1.5	2	710	74	0.71	4.4	5	20.8	1.8	2.1	24
132S8	2.2	3	720	75	0.72	6	6	29.6	1.8	2.1	38
132M8	3	4	720	77	0.74	7.8	6	40.4	1.8	2.2	44
160M1-8	4	5.5	720	80	0.74	10.3	6.6	53.8	1.9	2	118
160M2-8	5.5	7.5	720	83.5	0.75	13.6	6.6	73	2	2	119
160L8	7.5	10	720	85	0.79	17.8	6.6	99.5	2	2	145
180L8	11	15	730	87.5	0.8	25.1	6.6	145.9	2	2	184
200L8	15	20	730	88	0.81	34.1	6.6	196.2	2	2	250
225S8	18.5	25	730	90	0.81	40.6	6.6	242	1.9	2	266
225M8	22	30	740	90.5	0.81	47.4	6.6	287.8	1.9	2	292
250M8	30	40	740	91	0.83	64	6.6	392.5	1.9	2	405
280S8	37	50	740	91.5	0.84	78	6.6	484	1.9	2	520
280M8	45	60	740	92	0.85	94	6.6	588	1.9	2	592
315S8	55	75	740	92.8	0.81	111	6.6	719	1.8	2	1000
315M8	75	100	740	93	0.81	151	6.6	968	1.8	2	1100
315L1-8	90	125	740	93.8	0.82	178	6.6	1161	1.8	2	1160
315L2-8	110	150	740	94	0.82	217	6.4	1419	1.8	2	1230
355M1-8	132	180	740	93.7	0.82	261	6.4	1703	1.8	2	1600
355M2-8	160	220	740	94.2	0.82	315	6.4	2065	1.8	2	1700
355L8	200	270	740	94.5	0.83	388	6.4	2581	1.8	2	1800
400M1-8	250	340	745	95	0.81	469	6.6	3205	1.2	3.4	3100
400M2-8	280	380	745	95	0.81	525	6.7	3589	1.2	3.1	3200
400L1-8	315	430	745	95	0.82	584	6.5	4038	1.2	3	3300
400L2-8	355	480	745	95	0.82	679	7	4551	1.3	3	3400
400L3-8	400	550	745	95.2	0.82	740	7.2	5127	1.3	3	3550

Specifications

MSE4 - three-phase electric motors



Specifications

MSE4 - three-phase electric motors

2p - 3000 rpm

Type	Power		Speed n [1 minute]	Efficiency			cos ϕ	Nom. current. In 400V [THE]	Starting current Is / In	Nom. torque Mn [Nm]	Starting torque Ms / Mn	Tilting torque Mmax / Mn	Weight [kg]
	[kW]	[HP]		η 100%	η 75%	η 50%							
MSE4-80A2	0.75	1	2910	83.5	83.3	80.5	0.82	1.58	7.5	2.46	2.6	3.0	10.6
MSE4-80B2	1.1	1.5	2910	85.2	85.0	83.5	0.83	2.25	8.5	3.61	2.6	3.2	12
MSE4-90S2	1.5	2	2920	86.5	86.2	85.0	0.84	2.98	8.5	4.91	2.5	3.2	17
MSE4-90L2	2.2	3	2920	88.0	87.8	86.5	0.85	4.25	8.5	7.20	2.6	3.2	21
MSE4-100L2	3	4	2920	89.1	89.2	88.5	0.87	5.59	8.5	9.81	2.7	3.3	28
MSE4-112M2	4	5.5	2920	90.0	89.8	87.8	0.88	7.29	8.6	13.1	2.6	3.0	38
MSE4-132SA2	5.5	7.5	2920	90.9	90.8	89.8	0.88	9.90	8.6	18.0	2.5	2.8	54
MSE4-132SB2	7.5	10	2925	91.7	91.5	90.5	0.88	13.4	8.5	24.5	2.5	3.0	61
MSE4-160MA2	11	15	2945	92.6	92.3	91.8	0.89	19.3	8.8	35.7	2.7	3.3	109
MSE4-160MB2	15	20	2945	93.3	93.0	91.9	0.89	26.1	9.0	48.6	2.6	3.3	119
MSE4-160L2	18.5	25	2950	93.7	93.0	92.0	0.89	32.0	9.0	59.9	2.7	3.3	130

4p - 1500 rpm

Type	Power		Speed n [1 minute]	Efficiency			cos ϕ	Nom. current. In 400V [THE]	Starting current Is / In	Nom. torque Mn [Nm]	Starting torque Ms / Mn	Tilting torque Mmax / Mn	Weight [kg]
	[kW]	[HP]		η 100%	η 75%	η 50%							
MSE4-80B4	0.75	1	1445	85.7	85.6	84.8	0.75	1.68	7.5	4.96	2.8	3.2	15
MSE4-90S4	1.1	1.5	1445	87.2	86.5	85.3	0.76	2.40	8.2	7.27	2.5	3.0	17
MSE4-90L4	1.5	2	1450	88.2	87.5	85.5	0.77	3.19	8.2	9.88	2.6	3.2	21
MSE4-100LA4	2.2	3	1455	89.5	88.9	87.3	0.81	4.38	8.2	14.4	2.8	3.3	31
MSE4-100LB4	3	4	1455	90.4	89.8	88.5	0.82	5.84	8.6	19.7	2.8	3.3	35
MSE4-112M4	4	5.5	1455	91.1	91.2	90.3	0.82	7.73	8.8	26.3	2.7	3.3	44
MSE4-132S4	5.5	7.5	1460	91.9	91.5	90.0	0.83	10.4	8.6	36.0	[2.7	3.6	56
MSE4-132M4	7.5	10	1460	92.6	92.5	91.3	0.84	13.9	8.6	49.1	2.8	3.6	65
MSE4-160M4	11	15	1465	93.3	92.9	91.5	0.85	20.0	8.8	71.7	2.8	3.3	124
MSE4-160L4	15	20	1465	93.9	93.5	91.9	0.86	26.8	8.8	97.8	2.8	3.3	131

Specifications

MSE4 - three-phase electric motors

6p - 1000 rpm

Type	Power		Speed n [1 minute]	Efficiency			cos ϕ	Nom. current.	Starting current	Nom. torque	Starting torque	Tilting torque	Weight [kg]
	[kW]	[HP]		η 100%	η 75%	η 50%		In 400V [THE]	Is / In	Mn [Nm]	Ms / Mn	Mmax / Mn	
MSE4-90S6	0.75	1	955	82.7	81.8	79.5	0.71	1.84	6.0	7.50	2.0	2.3	17
MSE4-90L6	1.1	1.5	955	84.5	83.6	81.5	0.73	2.57	6.0	11.00	2.5	3.0	23
MSE4-100L6	1.5	2	960	85.9	85.0	82.5	0.73	3.45	6.5	14.92	2.5	2.9	31
MSE4-112M6	2.2	3	965	87.4	87.0	85.4	0.74	4.91	6.6	21.77	2.2	2.6	41
MSE4-132S6	3	4	968	88.6	88.1	86.5	0.74	6.60	7.8	29.60	2.5	3.0	52
MSE4-132MA6	4	5.5	968	89.5	88.5	86.8	0.74	8.72	7.8	39.46	2.3	2.6	62
MSE4-132MB6	5.5	7.5	968	90.5	89.9	87.5	0.75	11.7	8.1	54.26	2.3	2.6	73
MSE4-160M6	7.5	10	970	91.3	90.7	88.5	0.79	15.0	7.8	73.84	2.4	3.0	138
MSE4-160L6	11	15	970	92.3	91.8	89.8	0.8	21.5	7.8	108.30	2.2	2.5	155



Specifications

MYT - single phase electric motors



Specifications

MSE4 - three-phase electric motors

2p - 3000 rpm

Type	Power		Speed	Nom. current.		Degree of effect	Nom. torque	Starting torque	Tilting torque	Starting current	Condenser	Weight
Type	Power [kW]	Power [kW]	n [1 / min]	I (230V) [THE]	cosφ	η %	Mn [Nm]	Ma / Mn	Ms / Mn	Ia	Cm (450V) [μF]	m [kg]
MYT56A2	0.09	0.12	2760	0.81	0.9	54	0.33	0.7	1.6	3	5	2.9
MYT56B2	0.12	0.18	2770	0.98	0.92	58	0.40	0.7	1.6	4	6	3.2
MYT63A2	0.18	0.25	2780	1.42	0.92	60	0.66	0.7	1.7	5	10	4
MYT63B2	0.25	0.37	2780	1.94	0.92	61	0.90	0.68	1.7	7	10	4.5
MYT71A2	0.37	0.5	2800	2.75	0.93	63	1.36	0.63	1.7	12	16	5.1
MYT71B2	0.55	0.75	2810	3.5	0.95	72	1.93	0.63	1.7	15	14	7.2
MYT80A2	0.75	1	2810	4.77	0.95	72	2.55	0.45	1.7	20	20	9.6
MYT80B2	1.1	1.5	2810	6.8	0.95	74	3.86	0.43	1.7	28	35	11
MYT90S2	1.5	2	2820	9.15	0.95	75	5.40	0.35	1.8	40	45	14
MYT90LA2	2.2	3	2820	13.08	0.95	77	7.80	0.35	1.8	60	70	16.5
MYT90LB2	3	4	2840	17.83	0.95	77	10.6	0.35	1.8	75	80	25

4p - 1500 rpm

Type	Power		Speed	Nom. current.		Degree of effect	Nom. torque	Starting torque	Tilting torque	Starting current	Condenser	Weight
Type	[kW]	[kW]	n [1 / min]	I (230V) [THE]	cosφ	η %	Mn [Nm]	Ma / Mn	Ms / Mn	Ia	Cm (450V) [μF]	m [kg]
MYT564	0.09	0.12	1370	1	0.9	40	0.66	0.75	1.6	3	5	3.3
MYT63A4	0.12	0.18	1380	1.15	0.93	45	0.79	1	1.6	3.5	6	4
MYT63B4	0.18	0.25	1380	1.7	0.99	48	1.31	1	1.5	5.5	10	4.7
MYT71A4	0.25	0.37	1380	2	0.93	60	1.8	1	1.5	8	10	6.5
MYT71B4	0.37	0.5	1380	3.2	0.92	55	2.72	1	1.5	10	16	7.7
MYT80A4	0.55	0.75	1400	3.7	0.98	64	3.86	0.52	1.7	15	14	8.9
MYT80B4	0.75	1	1410	5.3	0.94	65	5.1	0.5	1.7	20	20	10.4
MYT90S4	1.1	1.5	1410	7	0.95	72	7.72	0.6	1.8	30	35	13.3
MYT90LA4	1.5	2	1420	9.3	0.96	73	10.8	0.5	1.8	40	45	16.2
MYT100LA4	2.2	3	1430	13	0.97	76	15.6	0.5	1.8	60	70	23.9
MYT100LB4	3	4	1440	17.8	0.97	77	21.2	0.5	1.7	76	100	32

Sizes

MS, MSE3, YE3 and MSE4 - three-phase electric motors



Sizes

MS, MSE3, YE3 and MSE4 - three-phase electric motors

B3 foot mounted

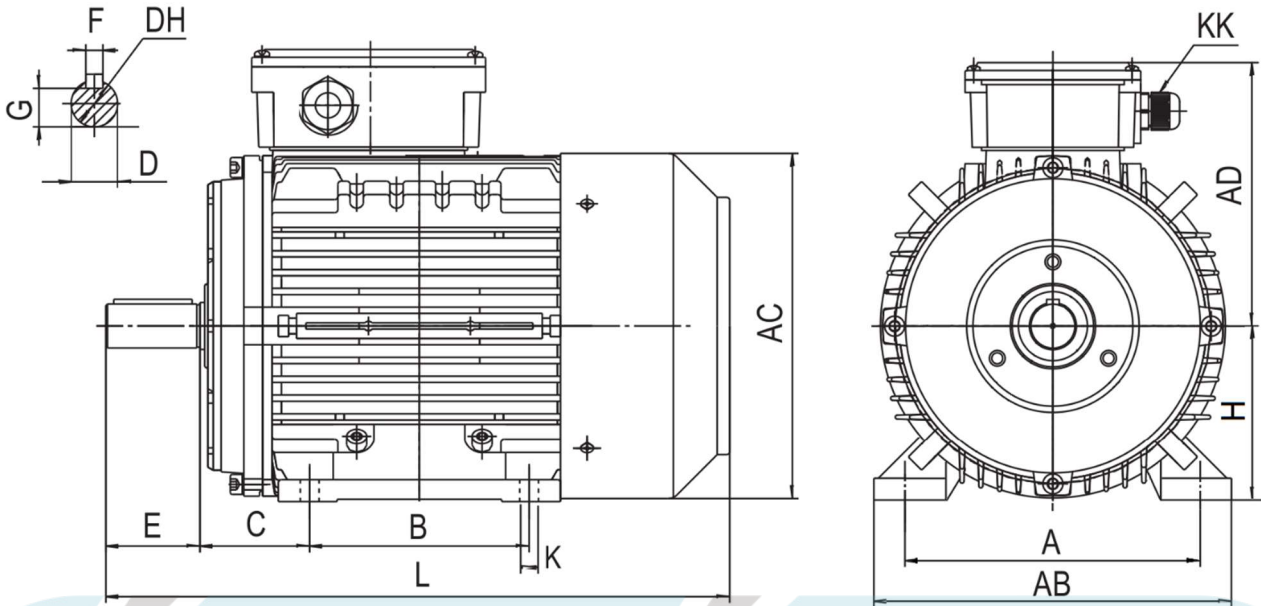

Size	Pole	A	AB	AC	AD	B	C	D	DH	E	F	G	H	K	KK	L	
56	2-4-6	90	115	110	100	71	36	9	M4X12	20	3	7,2	56	6	M20 X 1,5	199	
63	2-4-6	100	135	130	111	80	40	11	M4X12	23	4	8,5	63	7		217	
71	2-4-6	112	150	145	118	90	45	14	M5X12	30	5	11	71	7		245	
80	2-4-6	125	160	158	130	100	50	19	M6X16	40	6	15,5	80	10X13		277	
90S	2-4-6	140	175	177	140	100	56	24	M8X19	50	8	20	90	10X13	M25 X 1,5	312	
90L	2-4-6	140	175	177	140	125	56	24	M8X19	50	8	20	90	10X13		337	
100	2-4-6	160	196	199	157	140	63	28	M10X22	60	8	24	100	12X16	M32 X 1,5	375	
112M	2-4-6	190	220	220	168	140	70	28	M10X22	60	8	24	112	12X16		397	
132S	2-4-6	216	252	261	187	140	89	38	M12X28	80	10	33	132	12X16	M40 X 1,5	460	
132M	2-4-6	216	252	261	187	178	89	38	M12X28	80	10	33		12X16		498	
160M	2-4-6	254	320	330	265	210	108	42	M16X36	110	12	37	160	14X19	M50 X 1,5	665	
160L	2-4-6					254			M16X36	110				37		14X19	685
180M	2-4-6	279	350	380	280	241	121	48	M16X36	110	14	42,5	180	14X19	M63 X 1,5	730	
180L	2-4-6					279			M16X36	110				42,5		14X19	775
200L	2-4-6	318	395	420	315	305	133	55	M20X42	110	16	49	200	18X25	M40 X 1,5	785	
225S	4	356	436	465	335	286	149	60	M20X42	140	18	53	225	18X25		840	
225M	2	356	436	465	335	311	149	55	M20X42	110	16	49		250	18X25	M50 X 1,5	830
	2-4-6							60	M20X42	140	18	53			18X25		860
250M	2	406	495	520	375	349	168	60	M20X42	140	18	53	280	24X33	M50 X 1,5	940	
	4-6							65	M20X42	140	18	58		24X33		945	
280S	2	457	550	570	405	368	190	65	M20X42	140	18	58	315	24X33	M50 X 1,5	970	
	4-6							75	M20X42	140	20	67,5		24X33		975	
280M	2	457	550	570	405	419	190	65	M20X42	140	18	58	355	24X33	M63 X 1,5	1010	
	4-6							75	M20X42	140	20	67,5		24X33		1015	
315S	2	508	630	620	500	406	216	65	M20X42	140	18	58	355	28X49	M63 X 1,5	1160	
	4-6							80	M20X42	170	22	71		28X49		1190	
315M	2	508	630	620	500	457	216	65	M20X42	140	18	58	355	28X49	M63 X 1,5	1270	
	4-6							80	M20X42	170	22	71		28X49		1300	
315L	2	508	630	620	500	508	216	65	M20X42	140	18	58	355	28X49	M63 X 1,5	1270	
	4-6							80	M20X42	170	22	71		28X49		1300	
355M	2	610	735	700	645	560	254	75	M24X50	140	20	67,5	355	28X49	M63 X 1,5	1500	
	4-6							100	M24X50	210	28	86		28X49		1630	
355L	2	610	735	700	645	630	254	75	M24X50	140	20	67,5	355	28X49	M63 X 1,5	1500	
	4-6							100	M24X50	210	28	86		28X49		1630	

Sizes

MS, MSE3, YE3 and MSE4 - three-phase electric motors

B14 small flange

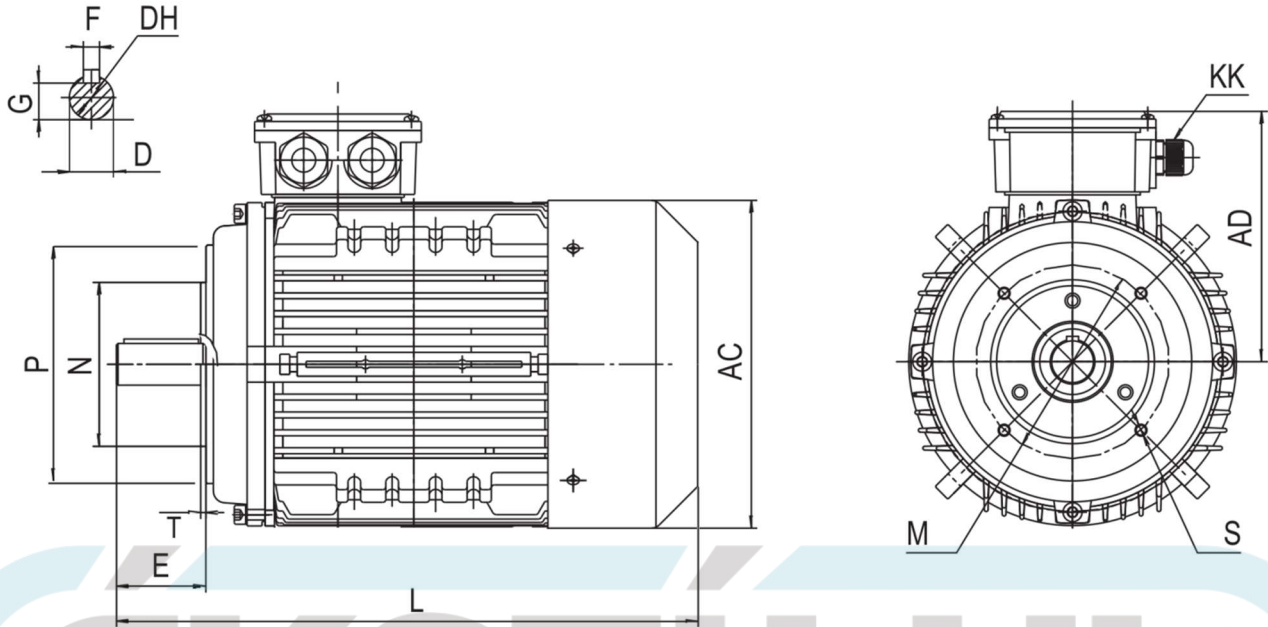

Size	Pole	THE	AB	AC	AD	B	C	D	DH	E	F	G	H	K	KK	L
56	2-4-6	110	100	9	M4X12	20	3	7,2	6	M20 X 1,5	199	65	50	80	M5	2,5
63	2-4-6	130	111	11	M4X12	23	4	8,5	7		217	75	60	90	M5	2,5
71	2-4-6	145	118	14	M5X12	30	5	11	7		245	85	70	105	M6	2,5
80	2-4-6	158	130	19	M6X16	40	6	15,5	10X13		277	100	80	120	M6	3
90S	2-4-6	177	140	24	M8X19	50	8	20	10X13		312	115	95	140	M8	3
90L	2-4-6	177	140	24	M8X19	50	8	20	10X13		337	115	95	140	M8	3
100	2-4-6	199	157	28	M10X22	60	8	24	12X16		375	130	110	160	M8	3,5
112	2-4-6	220	168	28	M10X22	60	8	24	12X16	M25 X 1,5	397	130	110	160	M8	3,5
132S	2-4-6	261	187	38	M12X28	80	10	33	12X16		460	165	130	200	M10	3,5
132M	2-4-6	261	187	38	M12X28	80	10	33	12X16		498	165	130	200	M10	3,5

Sizes

MS, MSE3, YE3 and MSE4 - three-phase electric motors

B5 large flange

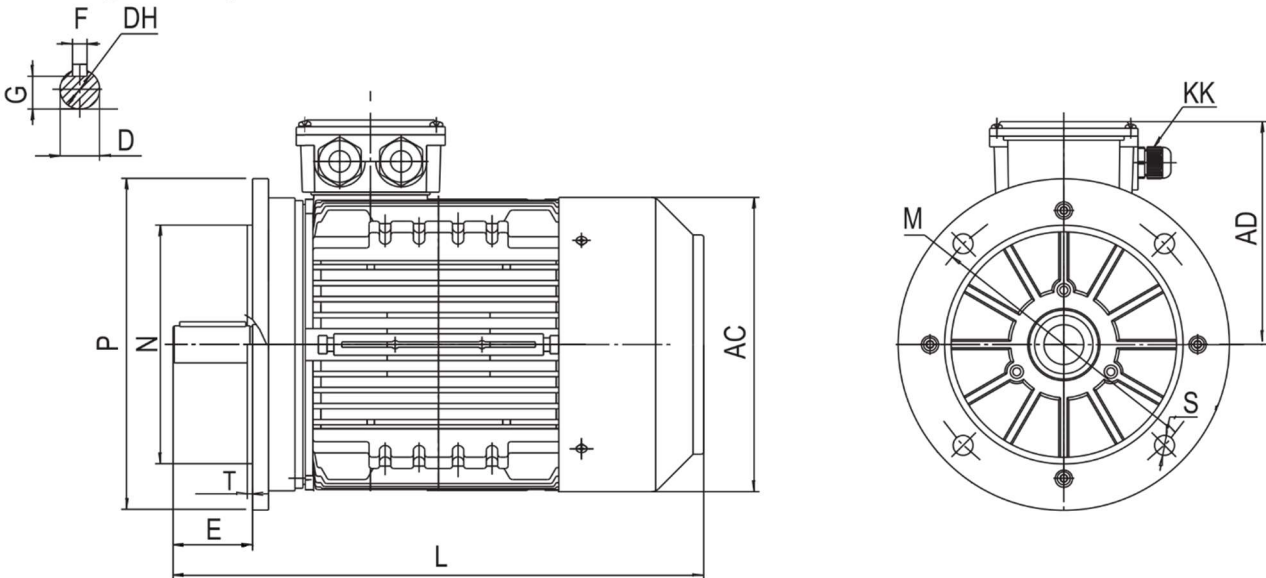

Size	Pole	AC	AD	D	DH	E	F	G	K	KK	L	M	N	P	S	T
56	2-4	110	100	9	M4X12	20	3	7,2	6	M20 X 1,5	199	100	80	120	7	3
63	2-4	130	111	11	M4X12	23	4	8,5	7		217	115	95	140	9,5	3
71	2-4	145	118	14	M5X12	30	5	11	7		245	130	110	160	9,5	3,5
80	2-4	158	130	19	M6X16	40	6	15,5	10X13		277	165	130	200	12	3,5
90S	2-4-6	177	140	24	M8X19	50	8	20	10X13		312	165	130	200	12	3,5
90L	2-4-6	177	140	24	M8X19	50	8	20	10X13		337	165	130	200	12	3,5
100	2-4-6	199	157	28	M10X22	60	8	24	12X16		375	215	180	250	15	4
112	2-4-6	220	168	28	M10X22	60	8	24	12X16		397	215	180	250	15	4
132S	2-4-6	261	187	38	M12X28	80	10	33	12X16		460	265	230	300	15	4
132M	2-4-6	261	187	38	M12X28	80	10	33	12X16		498	265	230	300	15	4
160M	2-4-6	330	265	42	M16X36	110	12	37	14X19	M32 X 1,5	665	300	250	350	18,5	5
160L	2-4-6				M16X36	110		37	14X19		685				18,5	5
180M	2-4-6	380	280	48	M16X36	110	14	42,5	14X19		730				18,5	5
180L	2-4-6				M16X36	110		42,5	14X19		775				18,5	5
200L	2-4-6	420	315	55	M20X42	110	16	49	18X25		785	350	300	400	18,5	5
225S	4	465	335	60	M20X42	140	18	53	18X25		840	400	350	450	18,5	5
225M	2	465	335	55	M20X42	110	16	49	18X25		830				18,5	5
	2-4-6			60	M20X42	140	18	53	18X25		860				18,5	5
250M	2	520	375	60	M20X42	140	18	53	24X33		940	500	450	550	18,5	5
	4-6			65	M20X42	140	18	58	24X33		945				18,5	5
280S	2	570	405	65	M20X42	140	18	58	24X33	970	18,5				5	
	4-6			75	M20X42	140	20	67,5	24X33	975	18,5				5	
280M	2	570	405	65	M20X42	140	18	58	24X33	1010	1015	18,5	5			
	4-6			75	M20X42	140	20	67,5	24X33	1015				18,5	5	
315S	2	620	500	65	M20X42	140	18	58	28X49	1160	600	550	660	24	6	
	4-6			80	M20X42	170	22	71	28X49	1190				24	6	
315M	2	620	500	65	M20X42	140	18	58	28X49	1270				1300	24	6
	4-6			80	M20X42	170	22	71	28X49	1300						
315L	2	620	500	65	M20X42	140	18	58	28X49	1270	1300	24	6			
	4-6			80	M20X42	170	22	71	28X49	1300				24	6	
355M	2	700	645	75	M24X50	140	20	67,5	28X49	1500	740	680	800	24	6	
	4-6			100	M24X50	210	28	86	28X49	1630				24	6	
355L	2	700	645	75	M24X50	140	20	67,5	28X49	1500				1630	24	6
	4-6			100	M24X50	210	28	86	28X49	1630						

Sizes

MS, MSE3, YE3 and MSE4 - three-phase electric motors

B34 foot-small flange

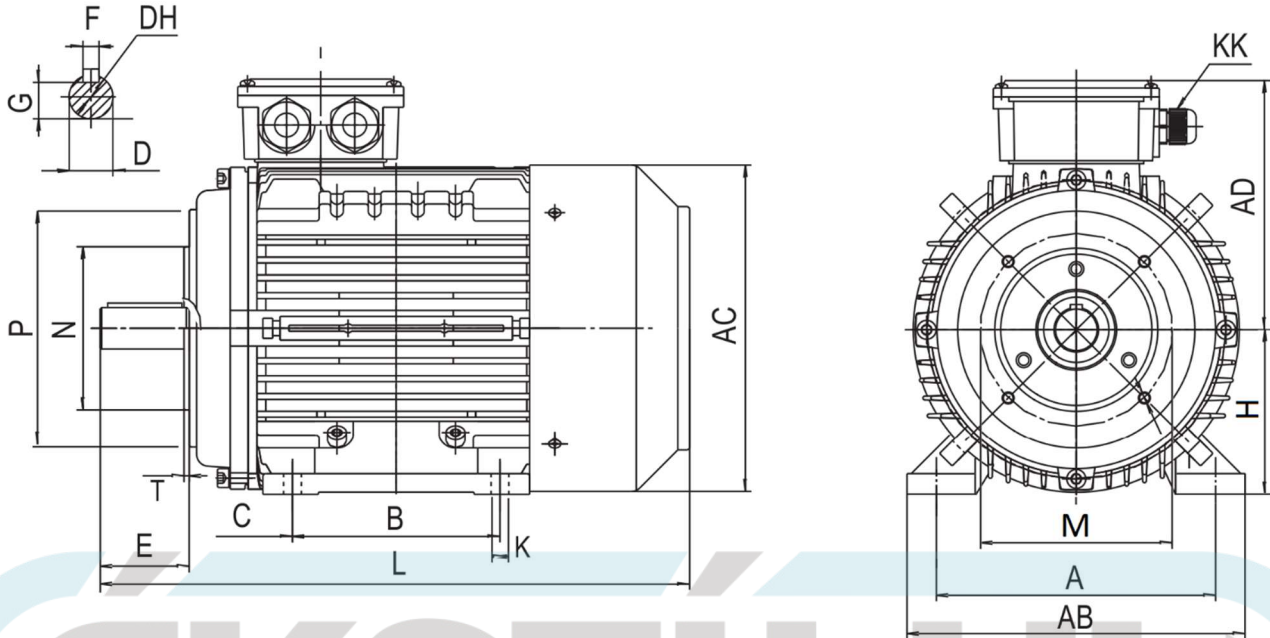

Size	Pole	A	AB	AC	AD	B	C	D	DH	E	F	G	H	K	KK	L	M	N	P	S	T
56	2-4-6	90	115	110	100	71	36	9	M4X12	20	3	7,2	56	6	M20 X 1,5	199	65	50	80	M5	2,5
63	2-4-6	100	135	130	111	80	40	11	M4X12	23	4	8,5	63	7		217	75	60	90	M5	2,5
71	2-4-6	112	150	145	118	90	45	14	M5X12	30	5	11	71	7		245	85	70	105	M6	2,5
80	2-4	125	160	158	130	100	50	19	M6X16	40	6	16	80	10X13		277	100	80	120	M6	3
90S	2-4-6	140	175	177	140	100	56	24	M8X19	50	8	20	90	10X13		312	115	95	140	M8	3
90L	2-4-6	140	175	177	140	125	56	24	M8X19	50	8	20	90	10X13		337	115	95	140	M8	3
100	2-4-6	160	196	199	157	140	63	28	M10X22	60	8	24	100	12X16		375	130	110	160	M8	3,5
112	2-4-6	190	220	220	168	140	70	28	M10X22	60	8	24	112	12X16	M25 X 1,5	397	130	110	160	M8	3,5
132S	2-4-6	216	252	261	187	140	89	38	M12X28	80	10	33	132	12X16		460	165	130	200	M10	3,5
132M	2-4-6	216	252	261	187	178	89	38	M12X28	80	10	33		12X16		498	165	130	200	M10	3,5

Sizes

MS, MSE3, YE3 and MSE4 - three-phase electric motors

B35 foot-large flange

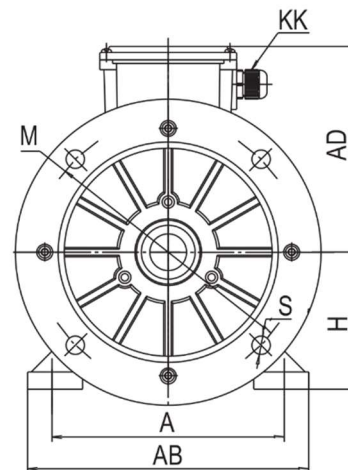
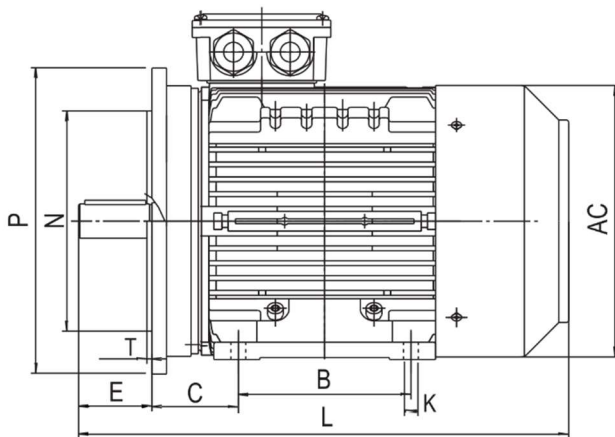
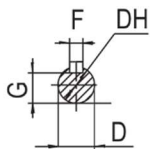

Size	Poles	A	AB	AC	AD	B	C	D	DH	E	F	G	H	K	KK	L	M	N	P	S	T				
56	2-4-6	90	115	110	100	71	36	9	M4X12	20	3	7,2	56	6	M20 X 1,5	199	100	80	120	7	3				
63	2-4-6	100	135	130	111	80	40	11	M4X12	23	4	8,5	63	7		217	115	95	140	9,5	3				
71	2-4-6	112	150	145	118	90	45	14	M5X12	30	5	11	71	7		245	130	110	160	9,5	3,5				
80	2-4	125	160	158	130	100	50	19	M6X16	40	6	16	80	10X13		277	165	130	200	12	3,5				
90S	2-4-6	140	175	177	140	100	56	24	M8X19	50	8	20	90	10X13		312	165	130	200	12	3,5				
90L	2-4-6	140	175	177	140	125	56	24	M8X19	50	8	20	90	10X13		337	165	130	200	12	3,5				
100	2-4-6	160	196	199	157	140	63	28	M10X22	60	8	24	100	12X16		375	215	180	250	15	4				
112	2-4-6	190	220	220	168	140	70	28	M10X22	60	8	24	112	12X16		397	215	180	250	15	4				
132S	2-4-6	216	252	261	187	140	89	38	M12X28	80	10	33	132	12X16		460	265	230	300	15	4				
132M	2-4-6	216	252	261	187	178	89	38	M12X28	80	10	33		12X16		498	265	230	300	15	4				
160M	2-4-6	254	320	330	265	210	108	42	M16X36	110	12	37	160	14X19	M32 X 1,5	665	300	250	350	19	5				
160L	2-4-6					254			M16X36	110				14X19		685						19	5		
180M	2-4-6	279	350	380	280	241	121	48	M16X36	110	14	43	180	14X19		730	19	5							
180L	2-4-6					279			M16X36	110				14X19					775	19	5				
200L	2-4-6	318	395	420	315	305	133	55	M20X42	110	16	49	200	18X25		785	350	300	400	19	5				
225S	4	356	436	465	335	286	149	60	M20X42	140	18	53	225	18X25		M40 X 1,5	840	400	350	450	19	5			
225M	2	356	436	465	335	311	149	55	M20X42	110	16	49		18X25			830						19	5	
	2-4-6							60	M20X42	140	18	53	18X25	860			19	5							
250M	2	406	495	520	375	349	168	60	M20X42	140	18	53	250	24X33			M50 X 1,5	940	500	450	550	19	5		
	4-6							65	M20X42	140	18	58		24X33				945						19	5
280S	2	457	550	570	405	368	190	65	M20X42	140	18	58	280	24X33	M63 X 1,5			970	600	550	660	19	5		
	4-6							75	M20X42	140	20	68		24X33				975						19	5
280M	2	457	550	570	405	419	190	65	M20X42	140	18	58	315	24X33				M63 X 1,5	1010	740	680	800	24	6	
	4-6							75	M20X42	140	20	68		24X33					1015						19
315S	2	508	630	620	500	406	216	65	M20X42	140	18	58	315	28X49					M63 X 1,5	1160	600	550	660	24	6
	4-6							80	M20X42	170	22	71		28X49		1190				24					
315M	2	508	630	620	500	457	216	65	M20X42	140	18	58	355	28X49		M63 X 1,5				1270	740	680	800	24	6
	4-6							80	M20X42	170	22	71		28X49						1300					
315L	2	508	630	620	500	508	216	65	M20X42	140	18	58	355	28X49			M63 X 1,5			1270	740	680	800	24	6
	4-6							80	M20X42	170	22	71		28X49						1300					
355M	2	610	735	700	645	560	254	75	M24X50	140	20	68	355	28X49	M63 X 1,5					1500	740	680	800	24	6
	4-6							100	M24X50	210	28	86		28X49						1630					
355L	2	610	735	700	645	630	254	75	M24X50	140	20	68	355	28X49				M63 X 1,5		1500	740	680	800	24	6
	4-6							100	M24X50	210	28	86		28X49						1630					

MSEJ - electric motors with brakes

EKSZIJ.HU

Sizes

MSEJ - electric motors with brakes

B3 foot mounted

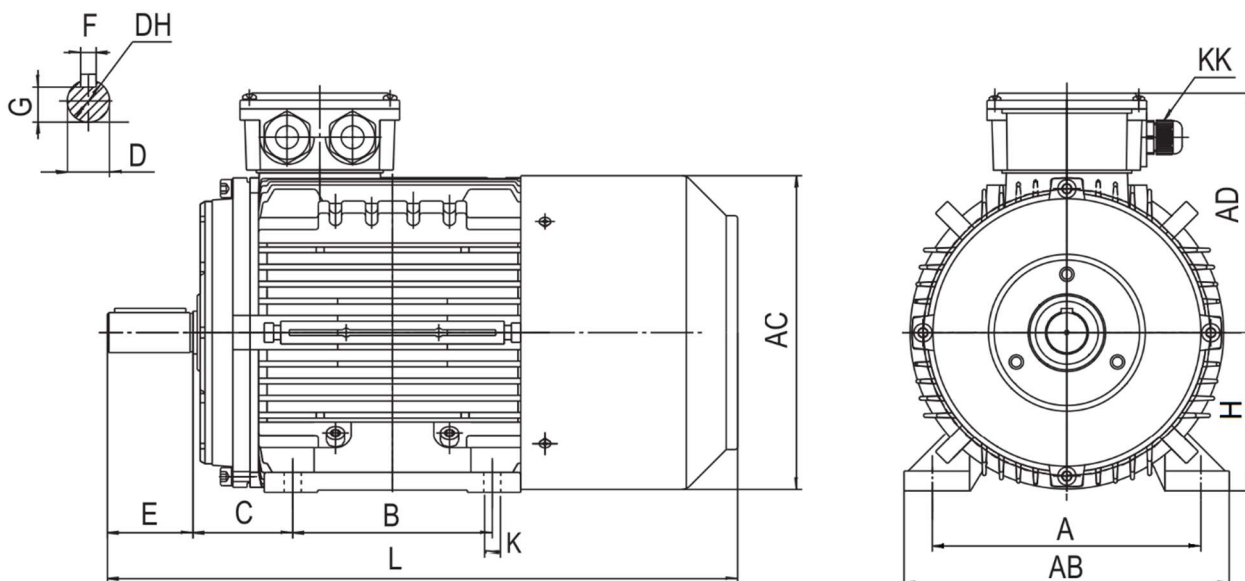

Méret	Pole	A	AB	AC	AD	B	C	D	DH	E	F	G	H	K	KK	L
56	2-4-6	90	115	110	100	71	36	9	M4X12	20	3	7,2	56	6	M20 X 1,5	220
63	2-4-6	100	135	130	111	80	40	11	M4X12	23	4	8,5	63	7		303
71	2-4-6	112	150	145	118	90	45	14	M5X12	30	5	11	71	7		303
80	2-4-6	125	160	158	130	100	50	19	M6X16	40	6	15,5	80	10X13		365
90S	2-4-6	140	175	177	140	100	56	24	M8X19	50	8	20	90	10X13	M20 X 1,5	400
90L	2-4-6	140	175	177	140	125	56	24	M8X19	50	8	20	90	10X13		425
100	2-4-6	160	196	199	157	140	63	28	M10X22	60	8	24	100	12X16	M25 X 1,5	480
112M	2-4-6	190	220	220	168	140	70	28	M10X22	60	8	24	112	12X16		502
132S	2-4-6	216	252	261	187	140	89	38	M12X28	80	10	33	132	12X16	M25 X 1,5	552
132M	2-4-6	216	252	261	187	178	89	38	M12X28	80	10	33		12X16		595
160M	2-4-6	254	320	330	265	210	108	42	M16X36	110	12	37	160	14X19	M32 X 1,5	725
160L	2-4-6					254			M16X36	110				37		14X19
180M	2-4-6	279	350	380	280	241	121	48	M16X36	110	14	42,5	180	14X19	M32 X 1,5	800
180L	2-4-6					279			M16X36	110				42,5		14X19
200L	2-4-6	318	395	420	315	305	133	55	M20X42	110	16	49	200	18X25	M40 X 1,5	913
225S	4	356	436	465	335	286	149	60	M20X42	140	18	53		18X25		940
225M	2	356	436	465	335	311	149	55	M20X42	110	16	49	225	18X25	M40 X 1,5	930
	2-4-6							60	M20X42	140	18	53		18X25		960
250M	2	406	495	520	375	349	168	60	M20X42	140	18	53	250	24X33	M50 X 1,5	1040
	4-6							65	M20X42	140	18	58		24X33		1045
280S	2	457	550	570	405	368	190	65	M20X42	140	18	58	280	24X33	M50 X 1,5	1070
	4-6							75	M20X42	140	20	67,5		24X33		1075
280M	2	457	550	570	405	419	190	65	M20X42	140	18	58	280	24X33	M50 X 1,5	1115
	4-6							75	M20X42	140	20	67,5		24X33		1120
315S	2	508	630	620	500	406	216	65	M20X42	140	18	58	315	28X49	M63 X 1,5	1280
	4-6							80	M20X42	170	22	71		28X49		1310
315M	2	508	630	620	500	457	216	65	M20X42	140	18	58	315	28X49	M63 X 1,5	1430
	4-6							80	M20X42	170	22	71		28X49		1460
315L	2	508	630	620	500	508	216	65	M20X42	140	18	58	315	28X49	M63 X 1,5	1430
	4-6							80	M20X42	170	22	71		28X49		1460
355M	2	610	735	700	645	560	254	75	M24X50	140	20	67,5	355	28X49	M63 X 1,5	1660
	4-6							100	M24X50	210	28	86		28X49		1790
355L	2	610	735	700	645	630	254	75	M24X50	140	20	67,5	355	28X49	M63 X 1,5	1660
	4-6							100	M24X50	210	28	86		28X49		1790

Sizes

MSEJ - electric motors with brakes

B14 small flange

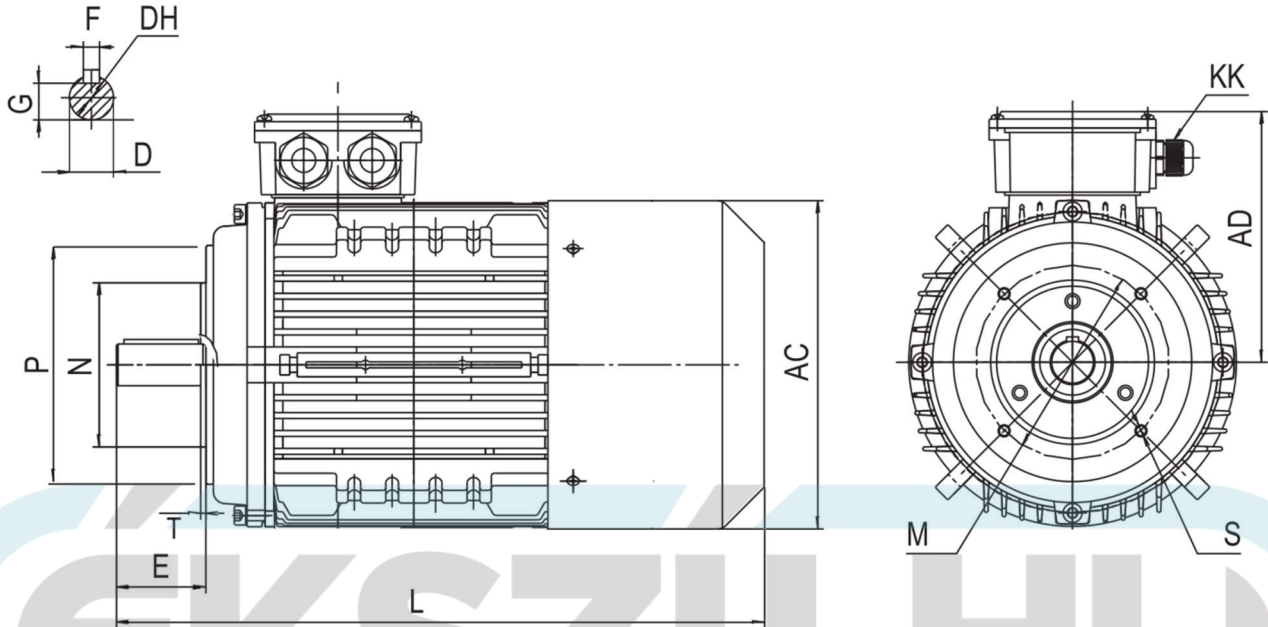

Méret	Pole	AC	AD	D	DH	E	F	G	K	KK	L	M	N	P	S	T
56	2-4-6	110	100	9	M4X12	20	3	7,2	6	M20 X 1,5	220	65	50	80	M5	2,5
63	2-4-6	130	111	11	M4X12	23	4	8,5	7		303	75	60	90	M5	2,5
71	2-4-6	145	118	14	M5X12	30	5	11	7		303	85	70	105	M6	2,5
80	2-4-6	158	130	19	M6X16	40	6	15,5	10X13		365	100	80	120	M6	3
90S	2-4-6	177	140	24	M8X19	50	8	20	10X13		400	115	95	140	M8	3
90L	2-4-6	177	140	24	M8X19	50	8	20	10X13		425	115	95	140	M8	3
100	2-4-6	199	157	28	M10X22	60	8	24	12X16		480	130	110	160	M8	3,5
112	2-4-6	220	168	28	M10X22	60	8	24	12X16	M25 X 1,5	502	130	110	160	M8	3,5
132S	2-4-6	261	187	38	M12X28	80	10	33	12X16		552	165	130	200	M10	3,5
132M	2-4-6	261	187	38	M12X28	80	10	33	12X16		595	165	130	200	M10	3,5

Sizes

MSEJ - electric motors with brakes

B5 large flange

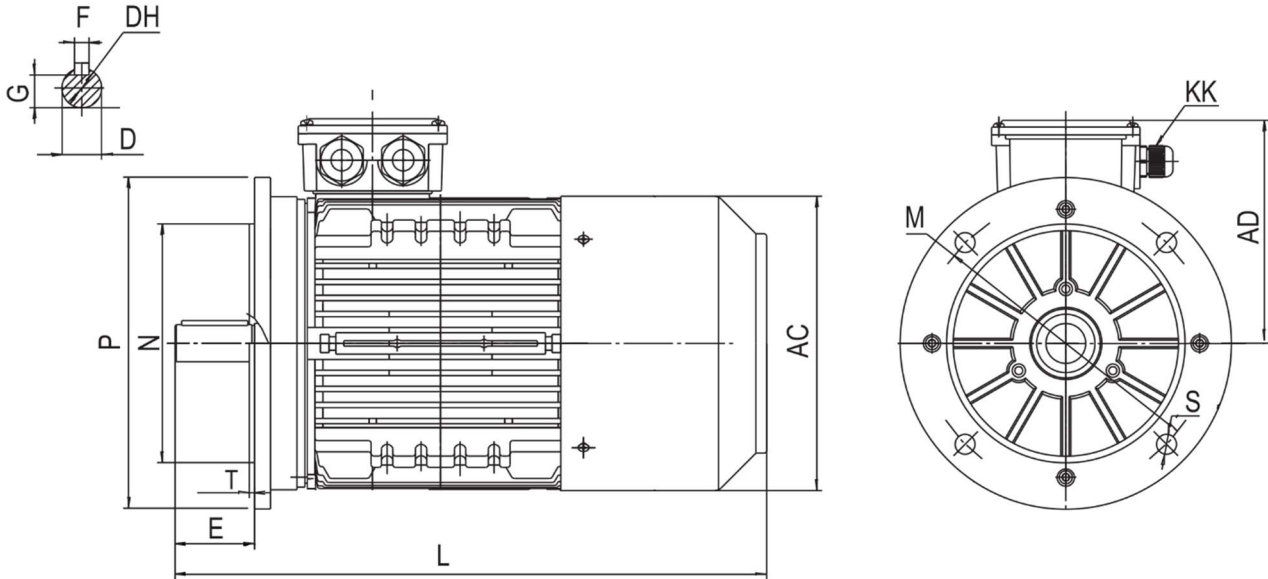

Méret	Pole	AC	AD	D	DH	E	F	G	K	KK	L	M	N	P	S	T			
56	2-4	110	100	9	M4X12	20	3	7,2	6	M20 X 1,5	220	100	80	120	7	3			
63	2-4	130	111	11	M4X12	23	4	8,5	7		303	115	95	140	9,5	3			
71	2-4	145	118	14	M5X12	30	5	11	7		303	130	110	160	9,5	3,5			
80	2-4	158	130	19	M6X16	40	6	15,5	10X13		365	165	130	200	12	3,5			
90S	2-4-6	177	140	24	M8X19	50	8	20	10X13		400	165	130	200	12	3,5			
90L	2-4-6	177	140	24	M8X19	50	8	20	10X13		425	165	130	200	12	3,5			
100	2-4-6	199	157	28	M10X22	60	8	24	12X16		480	215	180	250	15	4			
112	2-4-6	220	168	28	M10X22	60	8	24	12X16		502	215	180	250	15	4			
132S	2-4-6	261	187	38	M12X28	80	10	33	12X16		552	265	230	300	15	4			
132M	2-4-6	261	187	38	M12X28	80	10	33	12X16		595	265	230	300	15	4			
160M	2-4-6	330	265	42	M16X36	110	12	37	14X19	M32 X 1,5	725	300	250	350	18,5	5			
160L	2-4-6				M16X36	110					745						18,5	5	
180M	2-4-6	380	280	48	M16X36	110	14	42,5	14X19		800	300	250	350	18,5	5			
180L	2-4-6				M16X36	110					845						18,5	5	
200L	2-4-6	420	315	55	M20X42	110	16	49	18X25		913	350	300	400	18,5	5			
225S	4	465	335	60	M20X42	140	18	53	18X25		M40 X 1,5	940	400	350	450	18,5	5		
225M	2	465	335	55	M20X42	110	16	49	18X25			930						18,5	5
	2-4-6			60	M20X42	140	18	53	18X25			960						18,5	5
250M	2	520	375	60	M20X42	140	18	53	24X33		M50 X 1,5	1040	500	450	550	18,5	5		
	4-6			65	M20X42	140	18	58	24X33			1045						18,5	5
280S	2	570	405	65	M20X42	140	18	58	24X33	1070		500	450	550	18,5	5			
	4-6			75	M20X42	140	20	67,5	24X33	1075							18,5	5	
280M	2	570	405	65	M20X42	140	18	58	24X33	1115		500	450	550	18,5	5			
	4-6			75	M20X42	140	20	67,5	24X33	1120							18,5	5	
315S	2	620	500	65	M20X42	140	18	58	28X49	M63 X 1,5		1280	600	550	660	24	6		
	4-6			80	M20X42	170	22	71	28X49			1310						24	6
315M	2	620	500	65	M20X42	140	18	58	28X49			1430	600	550	660	24	6		
	4-6			80	M20X42	170	22	71	28X49			1460						24	6
315L	2	620	500	65	M20X42	140	18	58	28X49		1430	600	550	660	24	6			
	4-6			80	M20X42	170	22	71	28X49		1460						24	6	
355M	2	700	645	75	M24X50	140	20	67,5	28X49		1660	740	680	800	24	6			
	4-6			100	M24X50	210	28	86	28X49		1790						24	6	
355L	2	700	645	75	M24X50	140	20	67,5	28X49		1660	740	680	800	24	6			
	4-6			100	M24X50	210	28	86	28X49		1790						24	6	

Sizes

MSEJ - electric motors with brakes

B34 foot-small flange

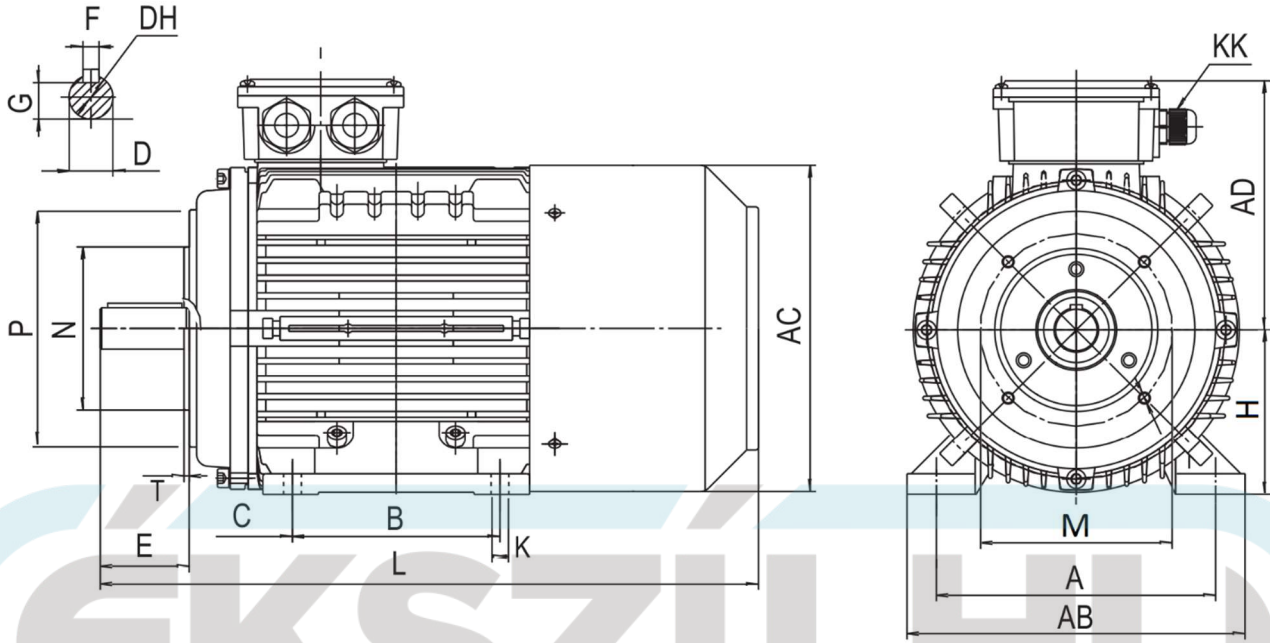

Méret	Pole	A	AB	AC	AD	B	C	D	DH	E	F	G	H	K	KK	L	M	N	P	S	T
56	2-4-6	90	115	110	100	71	36	9	M4X12	20	3	7,2	56	6	M20 X 1,5	220	65	50	80	M5	2,5
63	2-4-6	100	135	130	111	80	40	11	M4X12	23	4	8,5	63	7		303	75	60	90	M5	2,5
71	2-4-6	112	150	145	118	90	45	14	M5X12	30	5	11	71	7		303	85	70	105	M6	2,5
80	2-4	125	160	158	130	100	50	19	M6X16	40	6	16	80	10X13		365	100	80	120	M6	3
90S	2-4-6	140	175	177	140	100	56	24	M8X19	50	8	20	90	10X13		400	115	95	140	M8	3
90L	2-4-6	140	175	177	140	125	56	24	M8X19	50	8	20	90	10X13		425	115	95	140	M8	3
100	2-4-6	160	196	199	157	140	63	28	M10X22	60	8	24	100	12X16		480	130	110	160	M8	3,5
112	2-4-6	190	220	220	168	140	70	28	M10X22	60	8	24	112	12X16	M25 X 1,5	502	130	110	160	M8	3,5
132S	2-4-6	216	252	261	187	140	89	38	M12X28	80	10	33	132	12X16		552	165	130	200	M10	3,5
132M	2-4-6	216	252	261	187	178	89	38	M12X28	80	10	33		12X16		595	165	130	200	M10	3,5

Sizes

MSEJ - electric motors with brakes

B35 foot-large flange

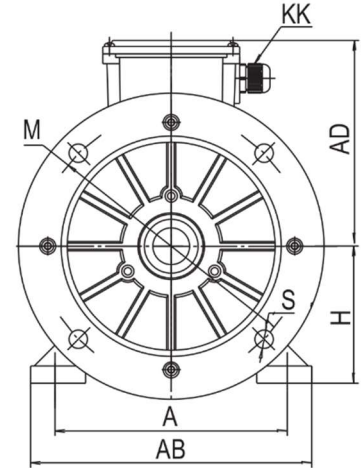
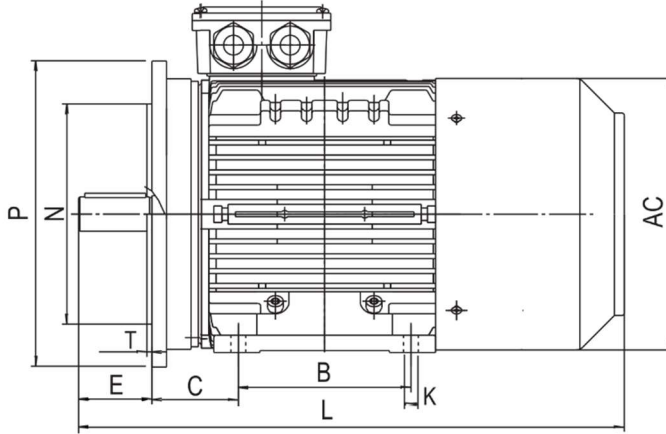
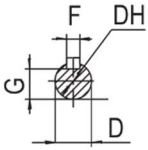

Méret	Pole	A	AB	AC	AD	B	C	D	DH	E	F	G	H	K	KK	L	M	N	P	S	T
56	2-4-6	90	115	110	100	71	36	9	M4X12	20	3	7,2	56	6	M20 X 1,5	220	100	80	120	7	3
63	2-4-6	100	135	130	111	80	40	11	M4X12	23	4	8,5	63	7		303	115	95	140	9,5	3
71	2-4-6	112	150	145	118	90	45	14	M5X12	30	5	11	71	7		303	130	110	160	9,5	3,5
80	2-4	125	160	158	130	100	50	19	M6X16	40	6	16	80	10X13		365	165	130	200	12	3,5
90S	2-4-6	140	175	177	140	100	56	24	M8X19	50	8	20	90	10X13		400	165	130	200	12	3,5
90L	2-4-6	140	175	177	140	125	56	24	M8X19	50	8	20	90	10X13		425	165	130	200	12	3,5
100	2-4-6	160	196	199	157	140	63	28	M10X22	60	8	24	100	12X16		480	215	180	250	15	4
112	2-4-6	190	220	220	168	140	70	28	M10X22	60	8	24	112	12X16	502	215	180	250	15	4	
132S	2-4-6	216	252	261	187	140	89	38	M12X28	80	10	33	132	12X16	M25 X 1,5	552	265	230	300	15	4
132M	2-4-6	216	252	261	187	178	89	38	M12X28	80	10	33		12X16		595	265	230	300	15	4
160M	2-4-6	254	320	330	265	210	108	42	M16X36	110	12	37	160	14X19	M32 X 1,5	725	300	250	350	19	5
160L	2-4-6					M16X36			110	14X19				745							
180M	2-4-6	279	350	380	280	241	121	48	M16X36	110	14	43	180	14X19	M40 X 1,5	800	400	350	450	19	5
180L	2-4-6					M16X36			110	14X19				845							
200L	2-4-6	318	395	420	315	305	133	55	M20X42	110	16	49	200	18X25	M50 X 1,5	913	350	300	400	19	5
225S	4	356	436	465	335	286	149	60	M20X42	140	18	53	225	18X25		940					
225M	2 2-4-6	356	436	465	335	311	149	55	M20X42	110	16	49		225	18X25	930	400	350	450	19	5
								60	M20X42	140	18	53	18X25		960	19					
250M	2 4-6	406	495	520	375	349	168	60	M20X42	140	18	53	250	24X33	M63 X 1,5	1040	500	450	550	19	5
								65	M20X42	140	18	58		24X33		1045					
280S	2 4-6	457	550	570	405	368	190	65	M20X42	140	18	58	280	24X33	M50 X 1,5	1070	500	450	550	19	5
								75	M20X42	140	20	68		24X33		1075					
280M	2 4-6	457	550	570	405	419	190	65	M20X42	140	18	58	280	24X33	M50 X 1,5	1115	500	450	550	19	5
								75	M20X42	140	20	68		24X33		1120					
315S	2 4-6	508	630	620	500	406	216	65	M20X42	140	18	58	315	28X49	M63 X 1,5	1280	600	550	660	24	6
								80	M20X42	170	22	71		28X49		1310					
315M	2 4-6	508	630	620	500	457	216	65	M20X42	140	18	58	315	28X49	M63 X 1,5	1430	600	550	660	24	6
								80	M20X42	170	22	71		28X49		1460					
315L	2 4-6	508	630	620	500	508	216	65	M20X42	140	18	58	315	28X49	M63 X 1,5	1430	600	550	660	24	6
								80	M20X42	170	22	71		28X49		1460					
355M	2 4-6	610	735	700	645	560	254	75	M24X50	140	20	68	355	28X49	M63 X 1,5	1660	740	680	800	24	6
								100	M24X50	210	28	86		28X49		1790					
355L	2 4-6	610	735	700	645	630	254	75	M24X50	140	20	68	355	28X49	M63 X 1,5	1660	740	680	800	24	6
								100	M24X50	210	28	86		28X49		1790					

MYT - single phase electric motors

EKSZIJ.HU

Sizes

MYT - single phase electric motors

B3 foot mounted

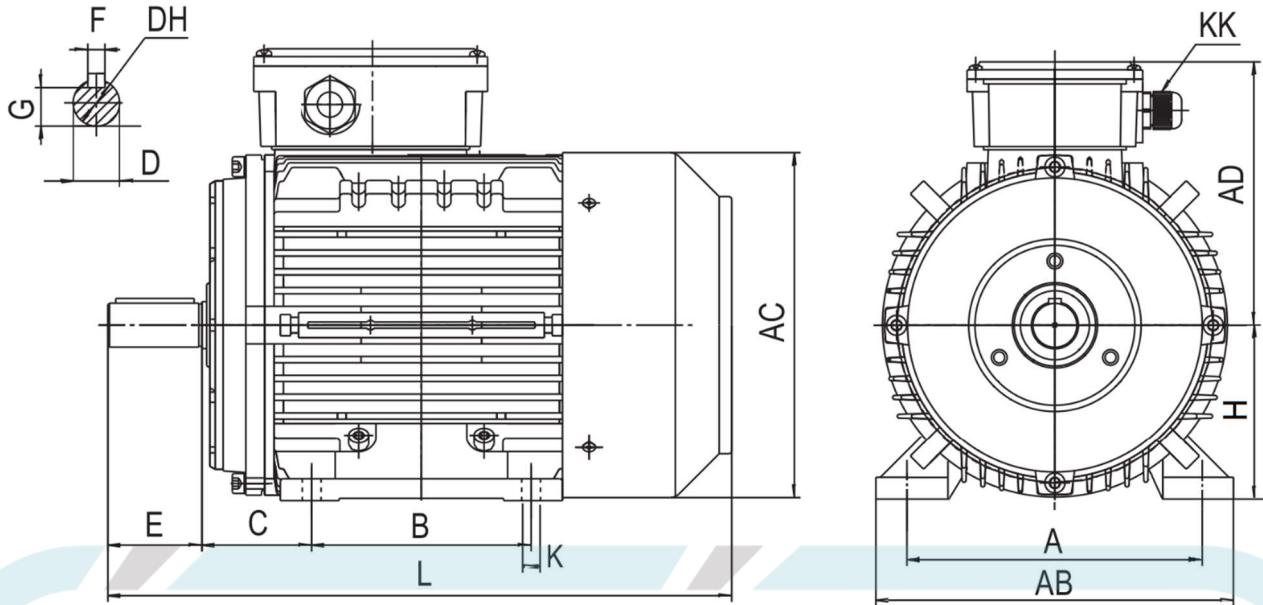

Size	Pole	A	AB	AC	AD	B	C	D	DH	E	F	G	H	K	KK	L	LB
56	2-4-6	90	115	110	100	71	36	9	M4X12	20	3	7,2	56	6	M20 X 1,5	199	220
63	2-4-6	100	135	130	114	80	40	11	M4X12	23	4	8,5	63	7		217	242
71	2-4-6	112	150	145	124	90	45	14	M5X12	30	5	11	71	7		245	265
80	2-4-6	125	160	158	152	100	50	19	M6X16	40	6	15,5	80	10X13		277	303
90S	2-4-6	140	175	177	157	100	56	24	M8X19	50	8	20	90	10X13		312	340
90L	2-4-6	140	175	177	157	125	56	24	M8X19	50	8	20	90	10X13		337	370
100	2-4-6	160	196	199	172	140	63	28	M10X22	60	8	24	100	12X16	375	414	

Sizes

MYT - single phase electric motors

B14 small flange

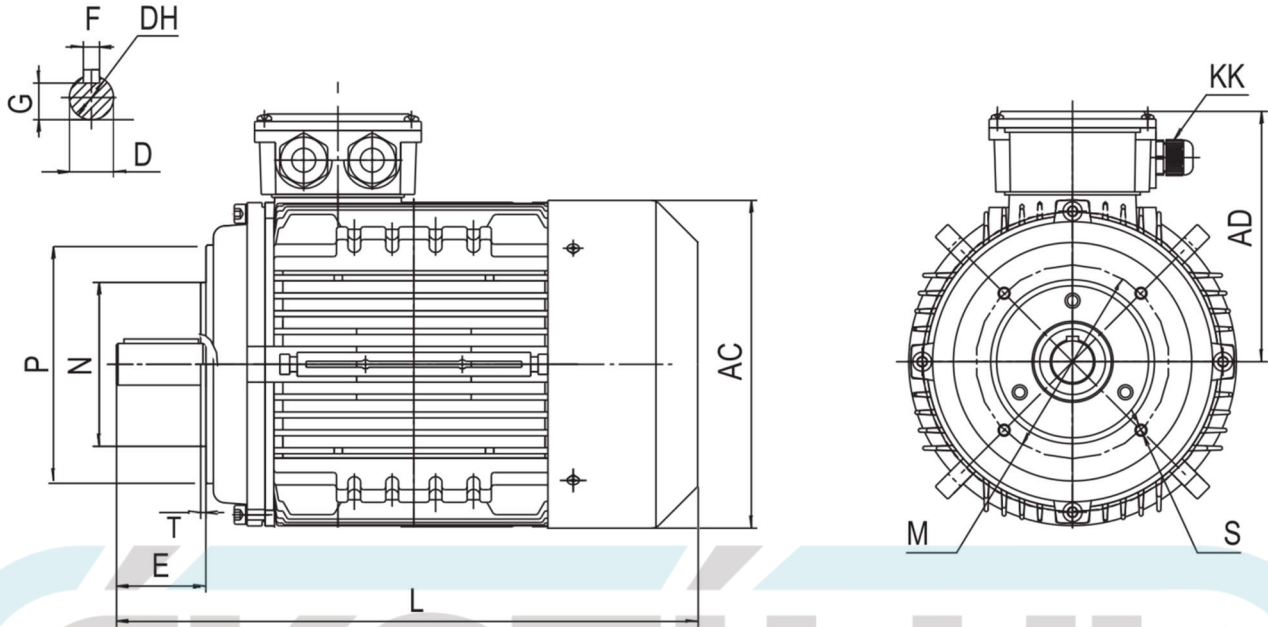

Size	Pole	AC	AD	D	DH	E	F	G	K	KK	L	LB	M	N	P	S	T
56	2-4-6	110	100	9	M4X12	20	3	7,2	6	M20 X 1,5	199	220	65	50	80	M5	2,5
63	2-4-6	130	114	11	M4X12	23	4	8,5	7		217	242	75	60	90	M5	2,5
71	2-4-6	145	124	14	M5X12	30	5	11	7		245	265	85	70	105	M6	2,5
80	2-4-6	158	152	19	M6X16	40	6	15,5	10X13		277	303	100	80	120	M6	3
90S	2-4-6	177	157	24	M8X19	50	8	20	10X13		312	340	115	95	140	M8	3
90L	2-4-6	177	157	24	M8X19	50	8	20	10X13		337	370	115	95	140	M8	3
100	2-4-6	199	172	28	M10X22	60	8	24	12X16		375	414	130	110	160	M8	3,5

Sizes

MYT - single phase electric motors

B5 large flange

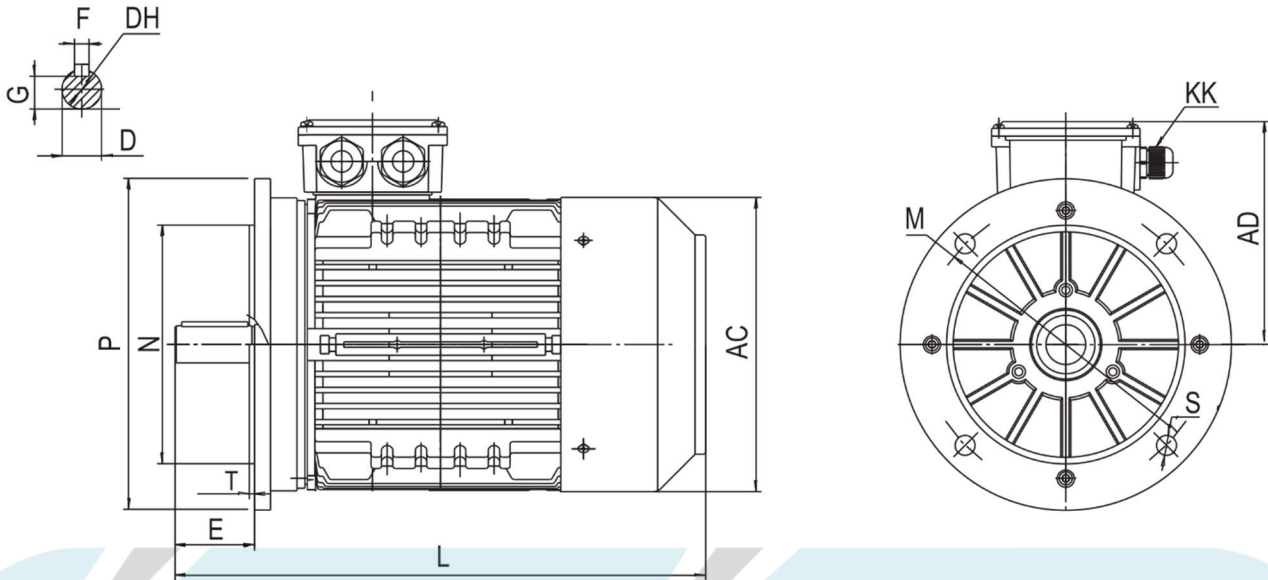

Size	Pole	AC	AD	D	DH	E	F	G	K	KK	L	LB	M	N	P	S	T
56	2-4	110	100	9	M4X12	20	3	7,2	6	M20 X 1,5	199	220	100	80	120	7	3
63	2-4	130	114	11	M4X12	23	4	8,5	7		217	242	115	95	140	9,5	3
71	2-4	145	124	14	M5X12	30	5	11	7		245	265	130	110	160	9,5	3,5
80	2-4	158	152	19	M6X16	40	6	15,5	10X13		277	303	165	130	200	12	3,5
90S	2-4-6	177	157	24	M8X19	50	8	20	10X13		312	340	165	130	200	12	3,5
90L	2-4-6	177	157	24	M8X19	50	8	20	10X13		337	370	165	130	200	12	3,5
100	2-4-6	199	172	28	M10X22	60	8	24	12X16	375	414	215	180	250	15	4	

Sizes

MYT - single phase electric motors

B34 foot-small flange

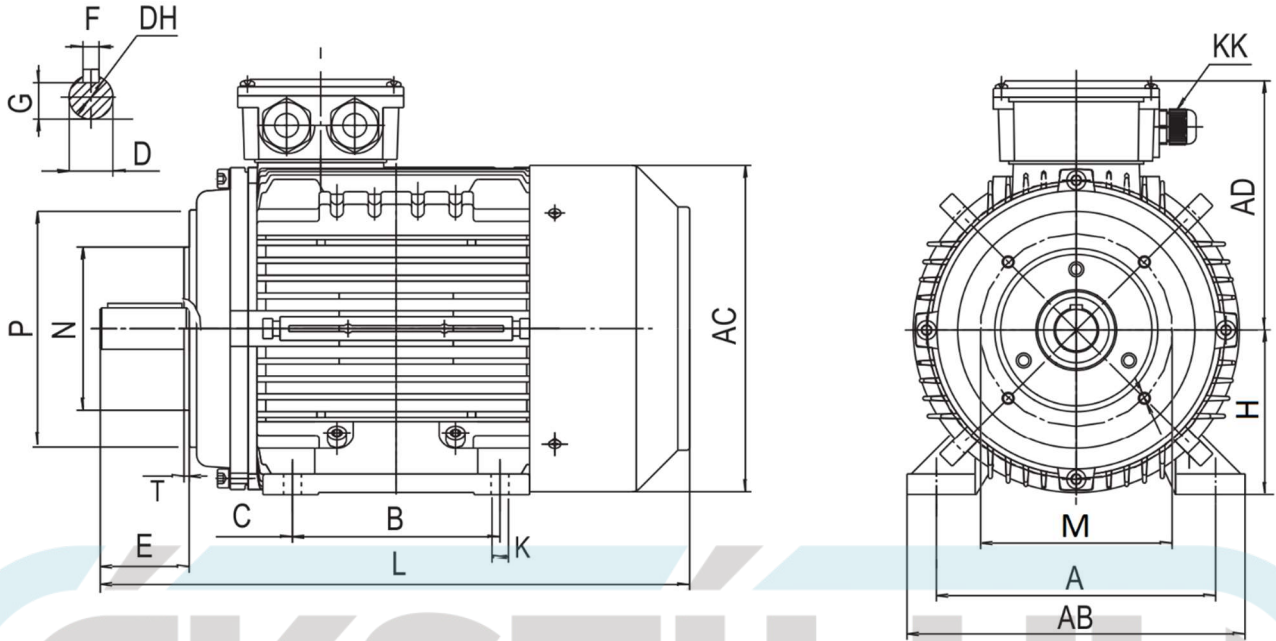

Size	Pole	A	AB	AC	AD	B	C	D	DH	E	F	G	H	K	KK	L	LB	M	N	P	S	T
56	2-4-6	90	115	110	100	71	36	9	M4X12	20	3	7,2	56	6	M20 X 1,5	199	220	65	50	80	M5	2,5
63	2-4-6	100	135	130	114	80	40	11	M4X12	23	4	8,5	63	7		217	242	75	60	90	M5	2,5
71	2-4-6	112	150	145	124	90	45	14	M5X12	30	5	11	71	7		245	265	85	70	105	M6	2,5
80	2-4	125	160	158	152	100	50	19	M6X16	40	6	16	80	10X13		277	303	100	80	120	M6	3
90S	2-4-6	140	175	177	157	100	56	24	M8X19	50	8	20	90	10X13		312	340	115	95	140	M8	3
90L	2-4-6	140	175	177	157	125	56	24	M8X19	50	8	20	90	10X13		337	370	115	95	140	M8	3
100	2-4-6	160	196	199	172	140	63	28	M10X22	60	8	24	100	12X16		375	414	130	110	160	M8	3,5

Sizes

MYT - single phase electric motors

B35 foot-large flange

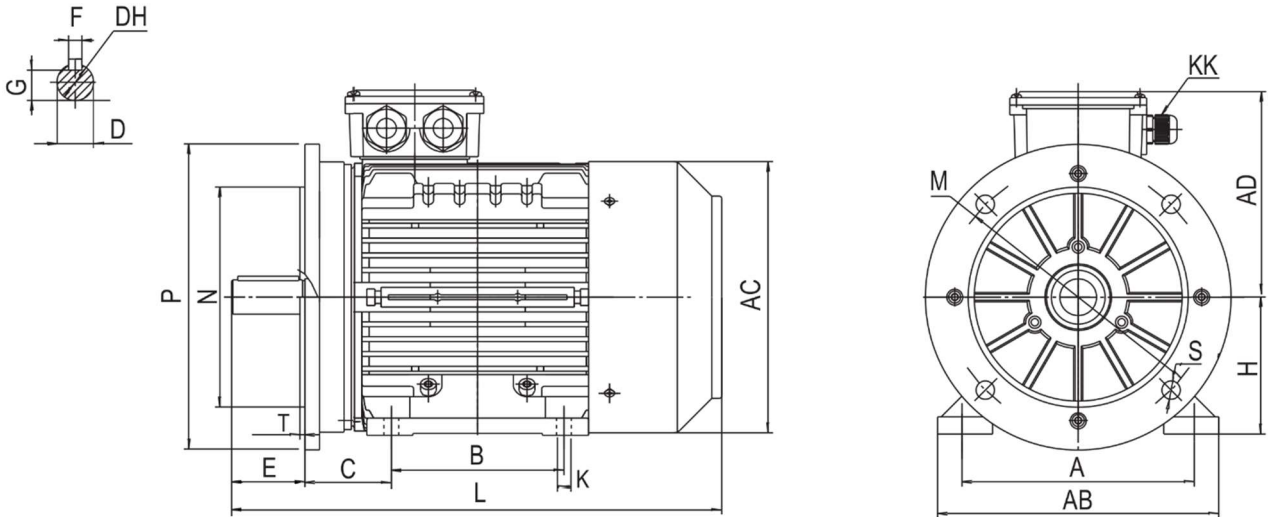

Size	Poles	A	AB	AC	AD	B	C	D	DH	E	F	G	H	K	KK	L	LB	M	N	P	S	T
56	2-4-6	90	115	110	100	71	36	9	M4X12	20	3	7,2	56	6	M20 X 1,5	199	220	100	80	120	7	3
63	2-4-6	100	135	130	114	80	40	11	M4X12	23	4	8,5	63	7		217	242	115	95	140	9,5	3
71	2-4-6	112	150	145	124	90	45	14	M5X12	30	5	11	71	7		245	265	130	110	160	9,5	3,5
80	2-4	125	160	158	152	100	50	19	M6X16	40	6	16	80	10X13		277	303	165	130	200	12	3,5
90S	2-4-6	140	175	177	157	100	56	24	M8X19	50	8	20	90	10X13		312	340	165	130	200	12	3,5
90L	2-4-6	140	175	177	157	125	56	24	M8X19	50	8	20	90	10X13		337	370	165	130	200	12	3,5
100	2-4-6	160	196	199	172	140	63	28	M10X22	60	8	24	100	12X16		375	414	215	180	250	15	4

ÉKSZIJ.HU